

Instructions for Use for Qualified Specialists in Orthopaedic Technology System Ankle Joints



NEURO VARIO-CLASSIC



NEURO VARIO



NEURO VARIO-SPRING

Download: www.fior-gentz.com

Content	Page
1. Information	4
2. Safety Instructions	4
2.1 Classification of the Safety Instructions	4
2.2 All Instructions for a Safe Handling of the System Ankle Joint	4
3. Use	7
3.1 Intended Use	7
3.2 Indication	7
3.3 Contraindication	7
3.4 Qualification	7
3.5 Application	7
3.6 Product Range	8
3.7 Combination Possibilities with Other System Joints	8
4. Joint Function	9
5. Scope of Delivery	9
6. Load	10
7. Tools for Assembling the System Joint	10
8. Assembly Instructions	11
8.1 Mounting the Functional Unit NEURO VARIO-SPRING	11
8.2 Mounting the System Stirrup	11
8.3 Mounting the Cover Plate	12
8.4 Checking the System Joint's Free Movement	12
8.5 Securing the Screws	13
9. Adjustment Options on the Orthosis	13
9.1 Adjustable Alignment and Range of Motion by Filing	13
9.2 Fine Adjustment of the Orthosis' Alignment	14
9.2.1 Securing the Adjusting Screw	14
9.3 Reading the Joint Angles	14
10. Connecting to the System Side Bar/System Anchor	15
11. Converting the System Ankle Joints	15
11.1 Conversion Options	15
11.2 Conversion NEURO VARIO-CLASSIC into NEURO VARIO-SPRING	15
11.3 Conversion NEURO VARIO-SPRING into NEURO VARIO-CLASSIC	15

12. Maintenance	16
12.1 Documentation of Maintenance in the Orthosis Service Passport	17
12.2 Replacing the Sliding Washers	17
12.3 Dirt Removal	17
13. Period of Use	17
14. Storage	18
15. Spare Parts	18
15.1 Exploded View Drawing NEURO VARIO-SPRING	18
15.2 Spare Parts for the NEURO VARIO-SPRING System Ankle Joint	19
15.3 Spare Parts for the NEURO VARIO-CLASSIC System Ankle Joint	20
15.4 Spare Parts for the NEURO VARIO System Ankle Joint	21
16. Disposal	22
17. Signs and Symbols	22
18. CE Conformity	23
19. Legal Information	23
20. Information for the Treatment Documentation	24
21. Handing Over the Orthosis	25

1. Information

These instructions for use are addressed to qualified specialists in orthopaedic technology and do not contain any notes about dangers which are obvious to them. To achieve maximum safety, please instruct the patient and/or care team in the use and maintenance of the product.



For a simplified illustration, all basic work steps are shown with the **NEURO VARIO-SPRING** system ankle joint (fig. 1) as an example. They can be transferred to all mentioned system joints.



fig. 1

2. Safety Instructions

2.1 Classification of the Safety Instructions

DANGER	Important information about a possible dangerous situation which, if not avoided, leads to death or irreversible injuries.
WARNING	Important information about a possible dangerous situation which, if not avoided, leads to reversible injuries that need medical treatment.
CAUTION	Important information about a possible dangerous situation which, if not avoided, leads to light injuries that do not need medical treatment.
NOTICE	Important information about a possible situation which, if not avoided, leads to damage of the product.

All serious incidents according to Regulation (EU) 2017/745 which are related to the product have to be reported to the manufacturer and to the competent authority of the Member State in which the qualified specialist in orthopaedic technology and/or the patient is established.

2.2 All Instructions for a Safe Handling of the System Ankle Joint

DANGER

Potential Traffic Accident Due to Limited Driving Ability

Advise the patient to gather information about all safety and security issues before driving a motor vehicle with orthosis. The patient should be able to drive a motor vehicle safely.

WARNING

Risk of Falling Due to Improper Handling

Inform the patient about the correct use of the system joint and potential dangers, especially with regards to:

- moisture and water as well as
- excessive mechanical stress (e.g. due to sports, increased activity or weight gain).

Also inform the patient that the system joint may only be demounted and maintained by a qualified specialist in orthopaedic technology. Any handling of the system joint and the orthosis by the patient that goes beyond the tasks described in these instructions for use for patients is not permitted.

WARNING

Risk of Falling Due to Improper Processing

Process the system joint according to the information in these instructions for use. Deviating processing and modifications of the system joint require the written consent of the manufacturer.

WARNING

Risk of Falling Due to Loosened Screws

Mount the cover plate to the system joint according to the assembly instructions in these instructions for use. Secure the screws with the specified torque and the corresponding adhesive and make sure that no sliding washers are damaged in the process.

WARNING

Risk of Falling Due to Incorrectly Selected System Components

Make sure that the system joint and the system components are not overloaded and are functionally adapted to the requirements and needs of the patient in order to avoid joint dysfunction.

WARNING

Risk of Falling Due to Permanent Higher Load

If patient data has changed (e.g. due to weight gain, growth or increased activity), recalculate the expected load on the system joint, plan the treatment again and, if necessary, produce a new orthosis.

WARNING

Risk of Falling Due to Improper Shoe/Wrong Shoe Pitch

Advise the patient to wear a shoe to which the orthosis is adjusted in order to avoid joint dysfunction.

WARNING

Risk of Falling Due to Incorrectly Adjusted Adjusting Screw

Adjust the adjusting screw according to the information in these instructions for use. Do not make a fine adjustment of more than 10° and secure the adjusting screw with the securing pin and the corresponding adhesive.

WARNING

Damage to the Anatomical Joint Due to Incorrect Position of the Joint's Mechanical Pivot Point

Determine the joint's mechanical pivot points correctly in order to avoid a permanent incorrect load on the anatomical joint. Please refer to the online tutorials on the FIOR & GENTZ website or contact Technical Support.

WARNING

Jeopardising the Therapy Goal by Not Providing the Necessary Free Movement

Check if the system joint moves freely in order to avoid restrictions of the joint function. Use suitable sliding washers according to the information in these instructions for use.

WARNING

Jeopardising the Therapy Goal by Incorrectly Filing the System Stirrup

If you need to file the system stirrup, note all information provided in these instructions for use. Do not file the system stirrup too far, especially for the dorsiflexion stop, as otherwise the forefoot lever is not activated. As a result, the patient's gait worsens due to a lack of stability. Therefore:

- file the system stirrup always gradually up to the required stop angles and
- do not file it more than 10° later on.

WARNING

Breakage of System Components Due to Predetermined Breaking Point on the System Stirrup

If you need to file the system stirrup, note all information provided in these instructions for use in order to avoid predetermined breaking points. File along the laser lines on the system stirrup.

WARNING

Breakage of the System Joint Due to Lack of System Anchor

Use a system anchor when producing the orthosis in order to ensure a secure integration of the system joint into the laminate. The system joint may break if it is integrated without a system anchor.

NOTICE

Limitation of the Joint Function Due to Improper Processing

Errors in processing can impair the joint function. Pay particular attention to:

- correctly connect the system side bar/system anchor with the system case in accordance with the production technique;
- grease the joint components only slightly and
- adhere to the maintenance intervals.

NOTICE

Limitation of the Joint Function Due to Improper Dirt Removal

Inform the patient on how to properly remove dirt from the orthosis and the system joint.

NOTICE

Limitation of the Joint Function Due to Lack of Maintenance

Respect the specified maintenance intervals in order to avoid joint dysfunction. Also inform the patient about the maintenance appointments to be respected. Enter the next maintenance appointment in the orthosis service passport of the patient.

3. Use

3.1 Intended Use

The FIOR & GENTZ system ankle joints are exclusively for use for orthotic fittings of the lower extremity. The system joints are only allowed to be used for producing an AFO or a KAFO. Every system joint influences the orthosis' function and thus also the function of the leg. The system joint may only be used for one fitting and must not be reused.

3.2 Indication

The indications for the treatment with an orthosis for the lower extremity are insecurities that lead to a pathological gait. This can be caused, for example, by paralyses, structurally conditioned deformities/malfunctions or as a result of physical trauma and/or surgery.

The physical conditions of the patient, such as muscle strength or activity level, are crucial for the orthotic treatment. An evaluation regarding the safe handling of the orthosis by the patient must be carried out.

All system ankle joints can also be used for the prosthetic treatment of patients with partial foot amputations. For this purpose, the orthosis produced for the patient by a qualified specialist in orthopaedic technology (custom-made product) is combined with a foot prosthesis. Further information can be found in the *Guide to Partial Foot Amputations* (see QR code, fig. 2).



fig. 2

3.3 Contraindication

The system joint is not suitable for treatments that were not described in paragraph 3.2, such as a treatment of the upper extremity or a treatment with a prosthesis or ortho-prosthesis that affects more than just part of the foot, for example after amputations of leg segments.

3.4 Qualification

The system joint must only be handled by a qualified specialist in orthopaedic technology.

3.5 Application

All FIOR & GENTZ system joints were developed for everyday life activities such as standing and walking. Extreme impact stress, which occurs for example during long jump, climbing and parachuting, is excluded.

.....

3.6 Product Range

These instructions for use provide information on the following system ankle joints:

NEURO
VARIO-CLASSIC NEURO VARIO-CLASSIC
⊕ — —

.....

NEURO
VARIO NEURO VARIO

.....

NEURO
VARIO-SPRING NEURO VARIO-SPRING

3.7 Combination Possibilities with Other System Joints

The system ankle joints can be combined with other system joints from our product range. The **NEURO VARIO** and **NEURO VARIO-CLASSIC** system ankle joints can be used as supporting joints for the **NEURO VARIO-SPRING**.

We recommend that you use the Orthosis Configurator when selecting all system components for your orthosis and follow the recommendations of the configuration result.

4. Joint Function

The system ankle joints have the following functions depending on the used system components:

System Component	Functions	System Joint
adjusting screw	dorsal (posterior adjusting screw): readjustment of the orthosis' alignment in plantar flexion	NEURO VARIO-CLASSIC NEURO VARIO
	ventral (anterior adjusting screw): readjustment of the orthosis' alignment in dorsiflexion	NEURO VARIO-CLASSIC NEURO VARIO NEURO VARIO-SPRING

System Component	Functions	System Joint
system stirrup which can be adjusted by filing	dorsal: adjustment of the orthosis' alignment in plantar flexion by filing the system stirrup along the laser lines	NEURO VARIO-CLASSIC NEURO VARIO
	ventral: adjustment of the orthosis' alignment in dorsiflexion by filing the system stirrup along the laser lines	NEURO VARIO-CLASSIC NEURO VARIO NEURO VARIO-SPRING

System Component	Functions	System Joint
coil spring	dorsiflexion assist	NEURO VARIO-SPRING

5. Scope of Delivery

Description	Quantity
system ankle joint (without figure)	1
securing pin (fig. 3)	
for NEURO VARIO-CLASSIC	1
for NEURO VARIO	2
for NEURO VARIO-SPRING	1
orthosis joint grease, 3g (without figure)	1
assembly/lamination dummy (fig. 4)	1

Appropriate system stirrups have to be ordered separately.



fig. 3



fig. 4

6. Load

The actual load on the system joints is based on the relevant patient data. The load and the appropriate system components can be determined by using the Orthosis Configurator. We recommend that you use the system components determined by the Orthosis Configurator when producing an orthosis and mind the recommended production technique. You will find information on the production techniques in the section "Online Tutorials" on the FIOR & GENTZ website.

7. Tools for Assembling the System Joint

Tools for all System Joints	System Width				
	10mm	12mm	14mm	16mm	20mm
torque screwdriver, 1–6Nm	x	x	x	x	x

Tools for the NEURO VARIO–CLASSIC	System Width		
	14mm	16mm	20mm
T20 hexalobular screwdriver/bit	x	x	x
hexagon socket, SW2,5	x	-	-
hexagon socket, SW3	-	x	x
pin punch, 3,5 x 0,6mm	x	x	x

Tools for the NEURO VARIO	System Width				
	10mm	12mm	14mm	16mm	20mm
T10 hexalobular screwdriver/bit	x	-	-	-	-
T15 hexalobular screwdriver/bit	-	x	-	-	-
T20 hexalobular screwdriver/bit	-	-	x	x	x
hexagon socket, SW2	x	x	-	-	-
hexagon socket, SW2,5	-	-	x	-	-
hexagon socket, SW3	-	-	-	x	x
pin punch, 3,5 x 0,6mm	x	x	x	x	x

Tools for the NEURO VARIO–SPRING	System Width		
	14mm	16mm	20mm
T20 hexalobular screwdriver/bit	x	x	x
hexagon socket, SW2,5	x	-	-
hexagon socket, SW3	-	x	x
assembly aid for cover plate	-	x	x
pin punch, 3,5 x 0,6mm	x	x	x

8. Assembly Instructions

The system joint is delivered fully assembled. All functions are checked beforehand. You have to disassemble the system joint for mounting it in the orthosis and for maintenance. To ensure an optimal functioning, follow the assembly instructions below. Secure all screws with the torque specified in paragraph 8.5.

You can find more information on the assembly in the online tutorial **Joint Assembly System Ankle Joints** (see QR code, fig. 5) on the FIOR & GENTZ website.

The assembly is illustrated with the **NEURO VARIO-SPRING** system ankle joint as an example.



fig. 5



Only use the FIOR & GENTZ orthosis joint grease to grease the system components.

8.1 Mounting the Functional Unit NEURO VARIO-SPRING

- 1 Assemble the functional unit. Mind the correct order: ball (1), pin (2), coil spring (3) (fig. 6).
- 2 Screw in the pressure screw (4) tightly. This fixes the ball, pin and coil spring in the spring duct of the cover plate.



Screw the pressure screw in or out carefully to prevent the coil spring from jumping out unintentionally.

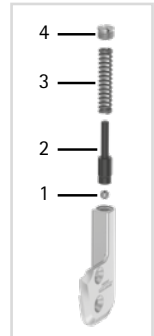

fig. 6

8.2 Mounting the System Stirrup

- 1 Before the assembly, clean the thread of the bearing nut and of the joint's upper part as well as the bores of the cover plate with LOCTITE® 7063 Super Clean. Allow the threads to air-dry for 10 minutes.
- 2 Grease the sliding surfaces of the bearing nut with orthosis joint grease.
- 3 Place the bearing nut into the intended hollow on the joint's upper part. The bearing nut must be fully inserted in the hollow (fig. 7).
- 4 Grease the first sliding washer slightly on both sides with orthosis joint grease.
- 5 Place the sliding washer onto the joint's upper part (fig. 8).
- 6 Mount the system stirrup (fig. 9).

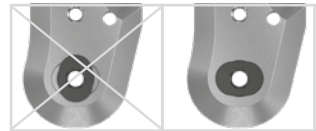

fig. 7

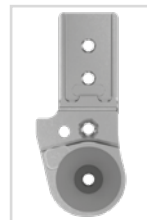

fig. 8

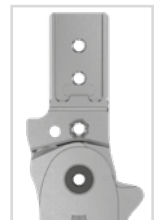

fig. 9

8.3 Mounting the Cover Plate



Make sure not to damage the sliding washer during assembly. Jammed sliding washer particles can cause lateral play in the system joint.

The steps 1-4 are only necessary for the **NEURO VARIO-SPRING** (16 and 20mm). For the **NEURO VARIO-CLASSIC** and the **NEURO VARIO**, skip these steps and continue the assembly at step 5.

- 1 Clamp the assembly aid for cover plate into a vice.
- 2 Place the cover plate with the ball on the pin of the assembly aid for cover plate.
- 3 Compress the coil spring by pulling the cover plate in your direction until the cover plate fits into the assembly aid for cover plate.
- 4 Remove the assembly aid for cover plate with the cover plate from the vice (fig. 10).



fig. 10



The assembly aid for cover plate can only be used for the **NEURO VARIO-SPRING** with a system width of 16mm or 20mm. A **NEURO VARIO-SPRING** with a system width of 14mm as well as the **NEURO VARIO-CLASSIC** and the **NEURO VARIO** can be mounted without the assembly aid for cover plate.

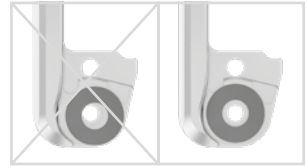

fig. 11

- 5 Apply spray adhesive on one side of the second sliding washer and adhere it to the cover plate (fig. 11).
- 6 Slightly grease the other side with orthosis joint grease.
- 7 Place the cover plate from the side on the system stirrup by using the assembly aid for cover plate (fig. 12).
- 8 Screw in the first countersunk flat head screw (axle screw, S1; fig. 13).
- 9 Screw in the second countersunk flat head screw (S2; fig. 14).
- 10 Grasp the assembly aid for cover plate at the top and carefully pull it up first and then sideways from the functional unit.

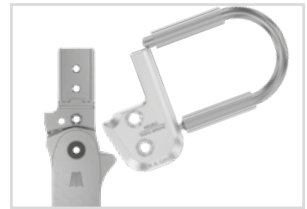

fig. 12

8.4 Checking the System Joint's Free Movement

Tighten the screws for the cover plate with the appropriate torque (see paragraph 8.5). Check if the system joint moves freely. If the system joint runs with lateral play, mount the next thicker sliding washer. If it does not move freely (it is jammed), mount the next thinner sliding washer.

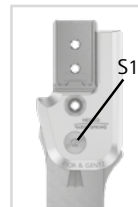

fig. 13

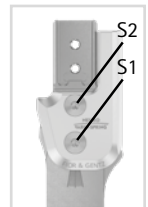

fig. 14

8.5 Securing the Screws

The screws are secured after the orthosis has been produced and tried on and before it is handed over to the patient.

- 1 Loosen the screws for the cover plate (fig. 14) after checking the system joint's free movement and remove them from the cover plate.
- 2 Apply a small drop of LOCTITE® 243 medium strength to the thread of the screws.
- 3 Secure the screws for the cover plate (fig. 14) with the torque corresponding to the system width.
- 4 Let the adhesive harden (final strength after approx. 24 hours).

Screws for Cover Plate	System Width				
	10mm	12mm	14mm	16mm	20mm
S1 (screw 1, axle screw)	1.5Nm	3Nm	4Nm	4Nm	4Nm
S2 (screw 2)	1.5Nm	3Nm	4Nm	4Nm	4Nm



The screws of the cover plate are not secured with the necessary torque at delivery. You can also find information on the torque in the openings of the cover plate.

9. Adjustment Options on the Orthosis

The orthosis can be individually adapted to the patient's needs with adjustable system ankle joints. The adjustments described do not influence each other and can be made independently of each other.



Mind the correct adjustment of the dorsiflexion stop when mounting the system ankle joint. It is decisive for the entire alignment of the orthosis. You can find more information on this in the online tutorial *AFO Alignment Guidelines* (see QR code, fig. 15) on the FIOR & GENTZ website.



fig. 15

9.1 Adjustable Alignment and Range of Motion by Filing

For system joints which can be adjusted by filing, the angle between the lower leg and foot can be changed by filing the system stirrup (maximum 10°; fig. 16). If you file the system stirrup at the plantar flexion stop, the angle between the lower leg and foot is reduced in plantar flexion. If you file the system stirrup at the dorsiflexion stop, the angle between the lower leg and foot is reduced in dorsiflexion.

If you file the system stirrup up to the round auxiliary line, the system ankle joint becomes free moving in dorsiflexion or plantar flexion.

If you do not need the conversion options (see paragraph 11), you can completely file off the nose along the vertical line.

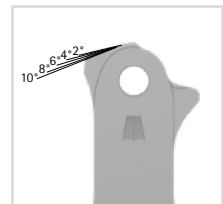

fig. 16

9.2 Fine Adjustment of the Orthosis' Alignment

Use the adjusting screw of the system joint to fine adjust the orthosis' alignment up to 10° (fig. 17). To do so, screw or unscrew the adjusting screw in the system joint. Note that no more than 10° fine adjustment is allowed. Otherwise, the surface pressure between adjusting screw and system stirrup can become so high that the screw is compressed and loses its function.



fig. 17

9.2.1 Securing the Adjusting Screw

The position of the adjusting screw cannot change due to the securing pin that is installed in the system joint. If the adjusting screw turns or loosens, it must be secured again with the securing pin.

- 1 Unscrew the adjusting screw out of the thread (fig. 17).
- 2 Demount the cover plate.
- 3 Drive out the premounted securing pin with a pin punch (fig. 18).
- 4 Mount the cover plate.
- 5 Apply some LOCTITE® 243 medium strength to the adjusting screw to secure it.
- 6 Screw in the adjusting screw up to the desired position (fig. 19).
- 7 Turn the worn position of the securing pin by about 90° (fig. 20).
- 8 Drive the securing pin from the back into the bore (fig. 21).
- 9 Let the adhesive harden (final strength after approx. 24 hours).

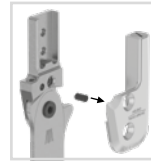

fig. 18



fig. 19

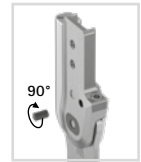

fig. 20



fig. 21



If the securing pin is deformed after the driving, put in a new one. If necessary, cut the new pin with a sharp knife so that it does not protrude. Depending on the system joint, one or two additional securing pins are included in the scope of delivery.

9.3 Reading the Joint Angles

There are markings (fig. 22) on all system joints and system stirrups which indicate the angle of the system components to each other. This allows you to check the individual normal posture (the orthosis' basic alignment), record the joint angle and compare later deviations. The joint angle in the individual normal posture must not be outside the degree markings.

The distances between the degree markings for each system width can be seen in the following table.

Degree Marking					
System Width	10mm	12mm	14mm	16mm	20mm
Degree	5°	5°	2°	2°	2°

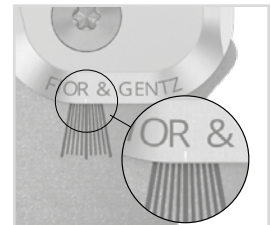

fig. 22

10. Connecting to the System Side Bar/System Anchor

The system side bar/system anchor must be connected to the system joint by adhering and screwing or screwing and wrapping in accordance with the production technique provided in the planning (fig. 23–25).

You can find more information in the Instructions for Use for Qualified Specialists in Orthopaedic Technology System Side Bars and System Anchors (see QR code, fig. 26).



fig. 23



fig. 24

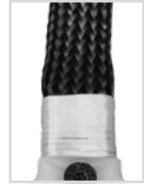

fig. 25



fig. 26

11. Converting the System Ankle Joints

11.1 Conversion Options

The following table shows the conversion options for the system ankle joints.

System Ankle Joint	Convertible into
NEURO VARIO-CLASSIC	NEURO VARIO-SPRING
NEURO VARIO-SPRING	NEURO VARIO-CLASSIC

11.2 Conversion NEURO VARIO-CLASSIC into NEURO VARIO-SPRING

- 1 Demount the cover plate of the NEURO VARIO-CLASSIC system joint.
- 2 Mount the functional unit of the NEURO VARIO-SPRING system joint in the correct system width (fig. 27).

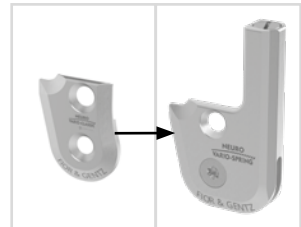

fig. 27

11.3 Conversion NEURO VARIO-SPRING into NEURO VARIO-CLASSIC

- 1 Demount the functional unit of the NEURO VARIO-SPRING system joint.
- 2 Mount the cover plate of the NEURO VARIO-CLASSIC system joint in the correct system width (fig. 28).

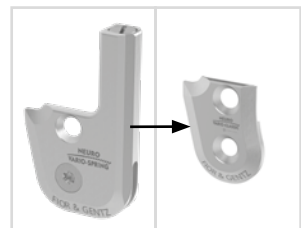

fig. 28

12. Maintenance

Check the system joint regularly for wear and functionality. In particular, check the joint components listed in the following table for the possible problems described and, if necessary, take the appropriate measures. Also check the functionality after every maintenance carried out. It must be possible to move the system joint without problems or unusual noises. Make sure that there is no lateral play and no play around the axis.

Joint Component	Potential Problem	Measure	Recommended Inspection, Potential Replacement*	Latest Replacement
sliding bushing	wear	replacing sliding bushing	every 6 months	every 18 months
sliding washer	wear	replacing sliding washer, see paragraph 12.2	every 6 months	every 18 months
coil spring**	wear	replacing coil spring	every 6 months	every 18 months
pin**	wear	replacing pin	every 6 months	every 36 months
cover plate**	wear	replacing cover plate	every 6 months	every 36 months
countersunk flat head screw with hexalobular socket**	wear	replacing countersunk flat head screw	every 6 months	every 36 months
bearing nut	wear	replacing bearing nut	every 6 months	every 36 months
functional unit***	wear or loss of function	replacing functional unit	every 6 months	every 36 months
system stirrup	wear or breakage	replacing system stirrup	every 6 months	every 48 months
securing pin	wear	replacing securing pin, see paragraph 9.2.1	every 6 months	if required
adjusting screw	wear	replacing adjusting screw	every 6 months	if required

* depending on the assessment of the distributor of the custom-made product regarding the patient's usage behaviour

** is part of the functional unit

*** included system components can be exchanged separately

Clean the thread of the bearing nut and of the joint's upper part as well as the bores of the cover plate with LOCTITE® 7063 Super Clean at every maintenance. Allow the threads to air-dry for 10 minutes.

Secure the screws for the cover plate with the appropriate torque and LOCTITE® 243 medium strength during every maintenance (see paragraph 8.5). Remove all adhesive residues first.

You can find the individual maintenance plans for system joints in the download area (see QR code, fig. 29) on the FIOR & GENTZ website.



fig. 29

12.1 Documentation of Maintenance in the Orthosis Service Passport

The patient receives an orthosis service passport (fig. 30) from a qualified specialist in orthopaedic technology when the orthosis is handed over. The orthosis must be checked regularly according to the specifications in the maintenance plan in order to maintain its function and to ensure the safety of the patient. The maintenance appointments are noted and confirmed in the orthosis service passport.



fig. 30

12.2 Replacing the Sliding Washers

Sliding washers are available in different thicknesses (e.g. GS2210-040 is 0.40mm thick). Each thickness has a different marking (fig. 31). You will find the article numbers of the premounted sliding washers on the back page of these instructions for use.

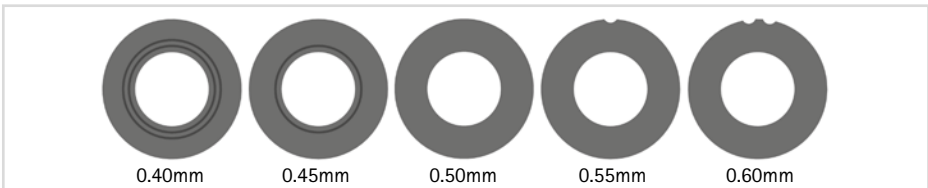

fig. 31

12.3 Dirt Removal

Dirt must be removed from the system joint when necessary and during regular maintenance. For this purpose, disassemble the system joint and clean the soiled system components with a dry cloth.

13. Period of Use

To guarantee a safe use and complete functionality as well as an unlimited period of use of the system joints, you must adhere to the following conditions:

- Adhere to the specified maintenance intervals without interruption and document each maintenance (see paragraph 12).
- Adhere to the determined maintenance conditions (see paragraph 12).
- Check the wear parts, as required, and exchange them in the defined intervals (see paragraph 12).
- Check the adjustment of the system joint during maintenance and correct it, if necessary (see paragraph 12).
- Check the functionality of the system joint during maintenance (see paragraph 12).
- The maximum load determined during the planning of the custom-made product shall not be exceeded by changes in the patient data (e.g. due to weight gain, growth or increased activity). If the determined maximum load on the system joints is exceeded, the system joint must no longer be used. When planning the custom-made product, expected changes in patient data need to be taken into account.
- The period of use of the system joints ends with the period of use of the custom-made product (orthosis).
- The multiple use of the system joint in another custom-made product is not allowed (see paragraph 19).

14. Storage

It is recommended to store the system joint in its original packaging until the custom-made product is produced.

15. Spare Parts

15.1 Exploded View Drawing NEURO VARIO-SPRING

The exploded view drawing of the NEURO VARIO-SPRING system ankle joint also serves as an exemplary illustration for the NEURO VARIO-CLASSIC and the NEURO VARIO system ankle joint.

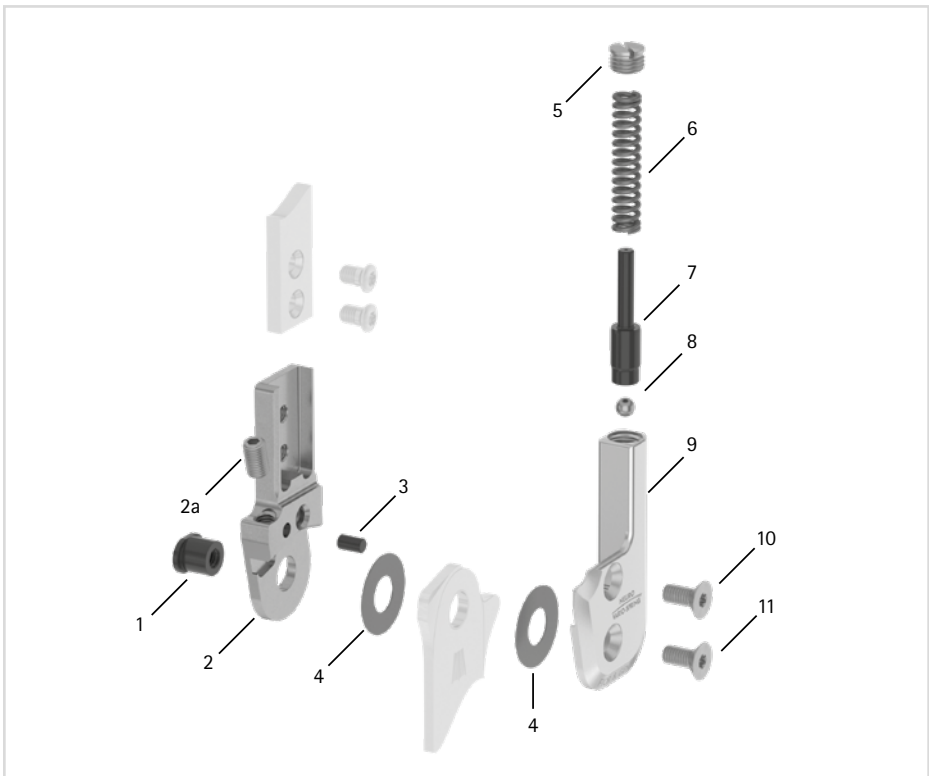

fig. 32

All system stirrups of the system ankle joints are delivered with an integrated sliding bushing.

15.2 Spare Parts for the NEURO VARIO-SPRING System Ankle Joint

Item	Article Number for System Width			Description
	14mm	16mm	20mm	
1	SB8559-L0620	SB9669-L0760	SB1069-L0810	bearing nut
2	SF0412-L/ST	SF0413-L/ST	SF0415-L/ST	upper part, left lateral or right medial, straight, steel (with adjusting screw)
2	SF0412-R/ST	SF0413-R/ST	SF0415-R/ST	upper part, left medial or right lateral, straight, steel (with adjusting screw)
2	SF0412-L/TI	SF0413-L/TI	SF0415-L/TI	upper part, left lateral or right medial, straight, titanium (with adjusting screw)
2	SF0412-R/TI	SF0413-R/TI	SF0415-R/TI	upper part, left medial or right lateral, straight, titanium (with adjusting screw)
2	SF0432-L/ST	SF0433-L/ST	SF0435-L/ST	upper part, left lateral or right medial, bent inwards, steel (with adjusting screw)
2	SF0432-R/ST	SF0433-R/ST	SF0435-R/ST	upper part, left medial or right lateral, bent inwards, steel (with adjusting screw)
2	SF0432-L/TI	SF0433-L/TI	SF0435-L/TI	upper part, left lateral or right medial, bent inwards, titanium (with adjusting screw)
2	SF0432-R/TI	SF0433-R/TI	SF0435-R/TI	upper part, left medial or right lateral, bent inwards, titanium (with adjusting screw)
2	SF0432-8L/ST	SF0433-8L/ST	SF0435-8L/ST	upper part, left lateral or right medial, bent outwards, steel (with adjusting screw)
2	SF0432-8R/ST	SF0433-8R/ST	SF0435-8R/ST	upper part, left medial or right lateral, bent outwards, steel (with adjusting screw)
2	SF0432-8L/TI	SF0433-8L/TI	SF0435-8L/TI	upper part, left lateral or right medial, bent outwards, titanium (with adjusting screw)
2	SF0432-8R/TI	SF0433-8R/TI	SF0435-8R/TI	upper part, left medial or right lateral, bent outwards, titanium (with adjusting screw)
2a	SC9605-L08ST	SC9606-L10ST	SC9606-L10ST	adjusting screw
3	GS4007	GS4007	GS4007	securing pin
4	GS2009-*	GS2210-*	GS2611-*	sliding washer*
5	SC2108-L04	SC2109-L05	SC2110-L05	pressure screw
6	FE1634-02	FE2836-02	FE2752-02	coil spring, golden
7	SF0342-75	SF0343-72	SF0345-81	pin
8	KU1005-ST	KU1005-ST	KU1005-ST	ball
9	SF0462-L/AL	SF0463-L/AL	SF0465-L/AL	cover plate, left lateral or right medial
9	SF0462-R/AL	SF0463-R/AL	SF0465-R/AL	cover plate, left medial or right lateral
10	SC1405-L10	SC1405-L11	SC1405-L12	countersunk flat head screw with hexalobular socket
11	SC1405-L10	SC1405-L11	SC1406-L12	countersunk flat head screw with hexalobular socket (axle screw)
5-11	SF4972-L/AL	SF4973-L/AL	SF4975-L/AL	functional unit, left lateral or right medial
5-11	SF4972-R/AL	SF4973-R/AL	SF4975-R/AL	functional unit, left medial or right lateral

* Sliding Washers NEURO VARIO-SPRING

Article Number for System Width		
14mm	16mm	20mm
Ø = 20mm	Ø = 22mm	Ø = 26mm
GS2009-040	GS2210-040	GS2611-040
GS2009-045	GS2210-045	GS2611-045
GS2009-050	GS2210-050	GS2611-050
GS2009-055	GS2210-055	GS2611-055
GS2009-060	GS2210-060	GS2611-060

15.3 Spare Parts for the NEURO VARIO-CLASSIC System Ankle Joint

The assignment of the items as shown in the exploded view drawing of the NEURO VARIO-SPRING system ankle joint serves as guidance. The spare parts of the NEURO VARIO-CLASSIC system ankle joint are not identical to the picture.

Item	Article Number for System Width			Description
	14mm	16mm	20mm	
1	SB8559-L0620	SB9669-L0760	SB1069-L0810	bearing nut
2	SF0412-L/ST	SF0413-L/ST	SF0415-L/ST	upper part, left lateral or right medial, straight, steel (with adjusting screw)
2	SF0412-R/ST	SF0413-R/ST	SF0415-R/ST	upper part, left medial or right lateral, straight, steel (with adjusting screw)
2	SF0412-L/TI	SF0413-L/TI	SF0415-L/TI	upper part, left lateral or right medial, straight, titanium (with adjusting screw)
2	SF0412-R/TI	SF0413-R/TI	SF0415-R/TI	upper part, left medial or right lateral, straight, titanium (with adjusting screw)
2	SF0432-L/ST	SF0433-L/ST	SF0435-L/ST	upper part, left lateral or right medial, bent inwards, steel (with adjusting screw)
2	SF0432-R/ST	SF0433-R/ST	SF0435-R/ST	upper part, left medial or right lateral, bent inwards, steel (with adjusting screw)
2	SF0432-L/TI	SF0433-L/TI	SF0435-L/TI	upper part, left lateral or right medial, bent inwards, titanium (with adjusting screw)
2	SF0432-R/TI	SF0433-R/TI	SF0435-R/TI	upper part, left medial or right lateral, bent inwards, titanium (with adjusting screw)
2	SF0432-8L/ST	SF0433-8L/ST	SF0435-8L/ST	upper part, left lateral or right medial, bent outwards, steel (with adjusting screw)
2	SF0432-8R/ST	SF0433-8R/ST	SF0435-8R/ST	upper part, left medial or right lateral, bent outwards, steel (with adjusting screw)
2	SF0432-8L/TI	SF0433-8L/TI	SF0435-8L/TI	upper part, left lateral or right medial, bent outwards, titanium (with adjusting screw)
2	SF0432-8R/TI	SF0433-8R/TI	SF0435-8R/TI	upper part, left medial or right lateral, bent outwards, titanium (with adjusting screw)
2a	SC9605-L08ST	SC9606-L10ST	SC9606-L10ST	adjusting screw
3	GS4007	GS4007	GS4007	securing pin

Item	Article Number for System Width			Description
	14mm	16mm	20mm	
4	GS2009-**	GS2210-**	GS2611-**	sliding washer**
9	SH0262-L/AL	SH0263-L/AL	SH0265-L/AL	cover plate, left lateral or right medial
9	SH0262-R/AL	SH0263-R/AL	SH0265-R/AL	cover plate, left medial or right lateral
10	SC1405-L10	SC1405-L11	SC1405-L12	countersunk flat head screw with hexalobular socket
11	SC1405-L10	SC1405-L11	SC1406-L12	countersunk flat head screw with hexalobular socket (axle screw)

** Sliding Washers NEURO VARIO-CLASSIC

	Article Number for System Width		
	14mm	16mm	20mm
	Ø = 20mm	Ø = 22mm	Ø = 26mm
	GS2009-040	GS2210-040	GS2611-040
	GS2009-045	GS2210-045	GS2611-045
	GS2009-050	GS2210-050	GS2611-050
	GS2009-055	GS2210-055	GS2611-055
	GS2009-060	GS2210-060	GS2611-060

15.4 Spare Parts for the NEURO VARIO System Ankle Joint

The assignment of the items as shown in the exploded view drawing of the NEURO VARIO-SPRING system ankle joint serves as guidance. The spare parts of the NEURO VARIO system ankle joint are not identical to the picture.

Item	Article Number for System Width					Description
	10mm	12mm	14mm	16mm	20mm	
1	SB6034-L0490	SB7049-L0590	SB8559-L0670	SB9669-L0760	SB1069-L0810	bearing nut
2	SF0200-ST	SF0241-ST	SF0242-ST	SF0243-ST	SF0245-ST	upper part, straight, steel (with adjusting screws)
2	-	SF0241-TI	SF0242-TI	SF0243-TI	SF0245-TI	upper part, straight, titanium (with adjusting screws)
2	SF0220-ST	SF0281-ST	SF0282-ST	SF0283-ST	SF0285-ST	upper part, bent, steel (with adjusting screws)
2	-	SF0281-TI	SF0282-TI	SF0283-TI	SF0285-TI	upper part, bent, titanium (with adjusting screws)
2a	SC9604-L06ST	SC9604-L06ST	SC9605-L08ST	SC9606-L10ST	SC9606-L10ST	adjusting screw
3	GS4007	GS4007	GS4007	GS4007	GS4007	securing pin
4	GS1206-***	GS1407-***	GS1609-***	GS2210-***	GS2611-***	sliding washer***

Item	Article Number for System Width					Description
	10mm	12mm	14mm	16mm	20mm	
9	SF0260-AL	SF0261-AL	SF0262-AL	SF0263-AL	SF0265-AL	cover plate
10	SC1403-L08	SC1404-L08	SC1405-L11	SC1405-L11	SC1405-L12	countersunk flat head screw with hexalobular socket
11	SC1403-L08	SC1404-L08	SC1405-L11	SC1405-L11	SC1406-L12	countersunk flat head screw with hexalobular socket (axle screw)

*** Sliding Washers NEURO VARIO

Article Number for System Width					
10mm	12mm	14mm	16mm	20mm	
Ø = 12mm	Ø = 14mm	Ø = 16mm	Ø = 22mm	Ø = 26mm	
GS1206-040	GS1407-040	GS1609-040	GS2210-040	GS2611-040	
GS1206-045	GS1407-045	GS1609-045	GS2210-045	GS2611-045	
GS1206-050	GS1407-050	GS1609-050	GS2210-050	GS2611-050	
GS1206-055	GS1407-055	GS1609-055	GS2210-055	GS2611-055	
GS1206-060	GS1407-060	GS1609-060	GS2210-060	GS2611-060	

16. Disposal

Dispose of the system joint and its individual parts properly. The product must not be disposed of with the residual waste (fig. 33). Please comply with the applicable national laws and local regulations for the proper recycling of recyclable materials.



fig. 33



For proper disposal, it is necessary to demount the system joint from the orthosis.

17. Signs and Symbols



CE labelling according to Regulation (EU) 2017/745 for medical devices



medical device



article number



manufacturer



batch code



serial number



follow the instructions for use



single patient – multiple uses



Unique Device Identifier – product identification number

18. CE Conformity

We declare that our medical devices as well as our accessories for medical devices are in conformity with the requirements of Regulation (EU) 2017/745. Therefore, the FIOR & GENTZ products bear the CE marking.

19. Legal Information

With the purchase of this product, our General Terms and Conditions of Business Transactions, Sales, Delivery and Payment will apply. The warranty expires, for example, if the product is mounted several times. Please note that the product is not supposed to be combined with other components or materials than with those recommended in the configuration result of the FIOR & GENTZ Orthosis Configurator. The combination of the product with products from other manufacturers is not permitted.

The information in these instructions for use is valid at the date of printing. The contained product information serves as guidelines. Subject to technical modifications.

All copy rights, particularly the distribution, copy and translation of these instructions for use or any part of them, must be authorised by FIOR & GENTZ Gesellschaft für Entwicklung und Vertrieb von orthopädiotechnischen Systemen mbH. Reprints, copies and any other electronic reproduction, even partial, must be authorised in writing by FIOR & GENTZ Gesellschaft für Entwicklung und Vertrieb von orthopädiotechnischen Systemen mbH.

.....

20. Information for the Treatment Documentation

Add these instructions for use to your treatment documentation!

Patient Data

Name	
Address	
Postcode, City	
Home Telephone	
Telephone at Work	
Insurance	
Insurance No.	
Attending Physician	
Diagnosis	

21. Handing Over the Orthosis

The qualified specialist in orthopaedic technology has also handed over the instructions for use for patients as well as the orthosis service passport to you as a patient, parent or care team. By means of these instructions for use, the functions and handling of the orthosis were explained to you in detail. You will find the next maintenance appointment in the orthosis service passport. Bring the orthosis service passport with you to every maintenance appointment.



Place, Date

Signature Patient

Leg Side

left right

Mounted Sliding Washer

1. GS _____ - _____

2. GS _____ - _____



PB1800-DE/GB-2024-03

