

Guide to Partial Foot Amputations

A Concept for the Prosthetic Treatment of Patients with Amputations below the Ankle Joint



Introduction

Every year, more than 50,000 people in Germany undergo a partial foot amputation [Spo, p. 5]. After an amputation, a prosthesis serves as a replacement for the lost limb. With it, the patient should be able to stand and walk as normally as possible again.

To achieve this goal, basic anatomical and physiological knowledge is necessary. The prosthetist has the demanding task of fitting the patient with a prosthesis in the best possible way. Depending on the amputation level, the prosthetic treatment is usually carried out using traditional treatment concepts. However, there is still a lot of untapped potential.

With the NEURO SWING system ankle joint, many traditional, inadequate prosthesis concepts for patients with partial foot amputations can be critically questioned. This guide has been created to provide a basis for the prosthetic treatment of patients with partial foot amputations and to show new possibilities. A targeted classification with three different types of treatment was developed to serve as a foundation for the present treatment concept. The resulting treatment suggestions are based on practical experience and scientific findings concerning the NEURO SWING system ankle joint.

Our guide does not claim to be perfect. Rather, it is intended to be the impetus to rethink the prosthetic treatment of patients with partial foot amputations.

We are grateful that we were able to count on the support of our customers during the planning and production of the first NEURO SWING partial foot prostheses. A big thank you also goes to the patients who had the courage to try out a new type of treatment.

With this guide we would like to show new ways for a better prosthetic treatment of patients with partial foot amputations. We cordially invite you to take this step with us.

Your FIOR & GENTZ team

cover page: patient (partial foot amputation according to Lisfranc, classification type 2), treated with a NEURO SWING partial foot prosthesis

Content

Partial Foot Amputations

Causes of Amputation	6
Statistics on Partial Foot Amputations	6
Complications	7

Therapy Goal

Physiological Stance and Gait	8
Working in an Interdisciplinary Team	10

The Prosthetic Treatment of Partial Foot Amputations

Requirements for a Prosthetic Treatment	12
Problems with Current Prosthetic Treatments	14
New Possibilities with the NEURO SWING	
Partial Foot Prosthesis	17

Functional Advantages of the NEURO SWING

Partial Foot Prosthesis

Precompressed Spring Units	18
Non-Precompressed Springs	19
Properties of the NEURO SWING	20

Biomechanical Changes

Loss of Bony Structures	28
Loss of Muscular Structures	29
Functional Shortening of the Forefoot Lever	31

Classification of Partial Foot Amputations 32

Treatment Suggestion

Treatment Suggestion for Type 1	34
Treatment Suggestion for Type 2	40
Treatment Suggestion for Type 3	46

Influencing the Gait by Adjusting the Spring Force 52

Glossary

Page	56
------	----

References

Page	64
------	----

An amputation is the complete or partial surgical removal of limbs. Depending on their severity, a division is made into major and minor amputations. In the case of the foot, it is considered a minor amputation if the anatomical ankle joint remains intact. A major amputation is associated with the loss of the anatomical ankle joint. In the case of a partial foot amputation, the distal part of the foot is amputated while the ankle joint remains intact.

The amputation should create a solid basis to restore the ability to walk. The amputation should be done as distally as possible to preserve maximum function. The anatomical lines (on which amputations are performed today) are named after the surgeons who established these amputations (see info box) [Bau, p. 136].

Amputations are always a last resort and is only carried out when there is no possibility of preserving the body part. An amputation may also be necessary if there are serious health consequences or severe chronic pain.

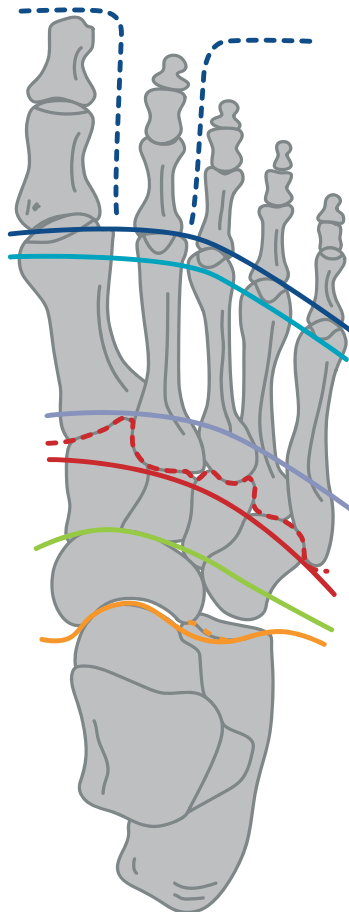

Exarticulation at the Metatarsophalangeal Joints

- removal of all toes at the base joint or
- removal of one toe (broken line)

Amputation according to Sharp

- long midfoot residual limb
- separation of the spongy area of the midfoot heads

Amputation according Sharp-Jäger

- short midfoot residual limb
- separation in the spongy area of the midfoot bases

Amputation at the Lisfranc Joint Line

- long tarsus residual limb
- removal of the metatarsal bones
→ uneven residual limb end (broken line),
hence rounding of the residual limb top (solid line)

Amputation according to Bona-Jäger

- short tarsal residual limb
- removal of the distal tarsal row
→ increased deformities in both ankle joints

Exarticulation at the Chopart Joint Line

- long rear foot residual limb
- removal of the navicular bone (os naviculare)
- ankle joint remains intact
→ muscularly caused deformity, can be compensated for by
an offset of the m. tibialis anterior

Causes of Amputation

- 87 % peripheral artery disease (PAD) and diabetic foot syndrome
- 4 % trauma
- 4 % tumors and infections
- 0,2 % congenital malformations (dysmelia)
- 5 % other causes

Statistics on Partial Foot Amputations

Due to the lack of a national amputation registry, exact figures for Germany are not available. According to a survey, 13,048 major and 40,992 minor amputations were performed in 2014. There was no differentiation made between diabetes and PAD as the primary cause. There was a significant decrease in major amputations with a simultaneous increase in minor amputations between 2005 and 2014 [Krö, p. 135].

Another source reports 55,595 amputations in 2015, including 29,153 toe/toe ray amputations and 8,688 foot, midfoot, or forefoot amputations [Spo, p. 5].

Amputations mainly affect males. The gender distribution is two-thirds men versus one-third women. The frequency of all amputations increases with age [Krö, S. 135].

Complications

Complications after an amputation are caused either by problems during surgery or a poor fit of the prosthetic device or incorrect footwear.

A poor prosthesis fit may result from an inadequate residual limb socket or an increased residual limb volume. The pressure then exerted on the residual limb can cause residual limb pain and/or a pressure ulcer. On the other hand, a decrease in the residual limb volume creates a lack of end contact in the prosthesis which can lead to the formation of oedema.

In surgical technique, for example, nonrounded bones in the residual limb or excessively tight soft tissue coverage can lead to soft tissue perforation and inflammation of the corresponding areas [Brü, p. 178f]. If the nerves are traumatised too much during the amputation, the patient usually suffers from residual limb and/or phantom limb pain later on [Krn, p. 486]. In many cases, such complications result in a residual limb revision, i.e. a subsequent amputation, which further shortens the residual limb and necessitates an adaptation of the prosthetic treatment.

Physiological Stance and Gait

The overall goal of a prosthetic treatment is to come as close as possible to a physiological stance and gait. The table below shows the physiological gait in its individual phases [Per, p. 9ff.]. Two factors significantly influence a safe stance and gait:

1. length of the residual limb
2. removal of muscles and tendons

To 1. The length of the residual limb has the following effects on stance and gait:











The shortening of the foot caused by the amputation results in a shortening of the forefoot lever depending on the length of the residual limb with the following effects:

- during stance: reduction of the support surface and thus a reduction of stability [Grei, p. 160]
- during gait: movement restrictions due to the changed force transmission (e.g. reduced step length, asymmetrical gait, reduced walking speed) [Dil, p. 25; For, p. 45]

To 2. The removal of muscles and tendons by amputation causes functional and structural limitations with the following effects:

- reduction of the range of motion of the upper and lower ankle joint
- deformity due to the muscular imbalance [Grei, p. 160]
- balance difficulties

Due to the muscular imbalance, contractures develop in most cases. Usually, the patient develops mechanisms to compensate for the lost functions [For, p. 45].

Division of the Physiological Gait into Individual Phases					According to Jacquelin Perry				
									
Term (Abbreviation)									
initial contact (IC)	loading response (LR)	early mid stance (MSt)	mid stance (MSt)	late mid stance (MSt)	terminal stance (TSst)	pre swing (PSw)	initial swing (ISw)	mid swing (MSw)	terminal swing (TSw)
Percentage of Stride									
0%	0-12%		12-31%		31-50%	50-62%	62-75%	75-87%	87-100%
Hip Angle									
20° flexion	20° flexion	10° flexion	5° extension	5° extension	20° extension	10° extension	15° flexion	25° flexion	20° flexion
Knee Angle									
5° flexion	15° flexion	10° flexion	5° flexion	5° flexion	10° flexion	40° flexion	60° flexion	25° flexion	5° flexion
Ankle Angle									
neutral position	5° plantar flexion	neutral position	5° dorsiflexion	5° dorsiflexion	10° dorsiflexion	15° plantar flexion	5° plantar flexion	neutral position	neutral position

Working in an Interdisciplinary Team

In order to achieve the therapy goal, the best possible approximation to a physiological stance and gait, the interdisciplinary team has to work closely together. In the case of partial foot amputations, the interdisciplinary team mainly consists of a physician (orthopaedist or orthopaedic surgeon), nursing staff, prosthetist or orthopaedic shoemaker and physiotherapist.

The physician and the nursing staff are usually the first point of contact for the patient in the event of an amputation and work to create a good basis for further treatment.

To obtain a healthy and resilient residual limb, the following points are important:

- optimal preparation (e.g. patient education, sensible choice of amputation level),
- careful execution of the operation (e.g. rounding of the ends of the bones on the residual limb) [Bau, p. 135],
- thorough follow-up (e.g. wound management).

The prosthetic treatment by the prosthetist or orthopaedic shoemaker should take the existing residual limb situation into account as best as possible. A qualified physiotherapy aims to use the remaining range of motion to its full extent by means of intensive gait re-education and to reduce any existing muscular imbalance.



Requirements for a Prosthetic Treatment

Depending on the amputation level, there are different biomechanical requirements for the prosthetic treatment. The more proximal the amputation, the more the anatomical ankle joint must be stabilised and the lost function must be compensated for.

A prosthesis for patients with partial foot amputations is designed to restore the function of the forefoot lever, to replace the lost muscle function and establish a stable, dynamic balance.

This is relevant for both a safe stance and for high and/or prolonged loads, e.g. long walking distances. In order to come as close as possible to a physiological gait, the residual mobility in the anatomical ankle joint should only be minimally restricted.

When walking with the prosthesis, shear forces on the residual limb should be avoided as much as possible. A potential subsequent amputation can severely change the biomechanical requirements for the prosthetic treatment. Likewise, one must expect a continuously increasing pes equinus position and supination.



Problems with Current Prosthetic Treatments

Sub-Ankle Prostheses (Treatments 1, 2 and 3)

All common sub-ankle prostheses allow good adhesion to the residual limb, which is achieved either by high static friction (for silicone prostheses) or a close-fitting heel cap (for Bellmann prostheses). However, because of this heel cap Bellmann prostheses are contraindicated for patients with a residual limb which cannot bear the full weight [Brü, p. 179]. It is also problematic that the missing function of the anatomical forefoot lever, which differs depending on the residual limb length, cannot be compensated for. To achieve a functional compensation, the prosthesis must be supplemented by a component above the ankle.

Above-Ankle Prostheses (Treatments 4 and 5)

Prostheses above the ankle enable a functional compensation in the form of a mechanical forefoot lever and thus the stabilisation of the anatomical ankle joint. However, the blocking of the physiological range of motion and the lack of dynamics in the anatomical ankle joint can provoke secondary problems such as contractures. In addition, a simple adaptation of the prosthetic treatment is not possible.

1. Toe Filler or Forefoot Replacement

A simple toe or forefoot replacement is used if one, several or all toes are lost. If the focus is on a cosmetic use, the replacement is usually made of silicone. Foam materials are used for a simple volume compensations [Dil, p. 1319]. If the big toe is lost, a functional compensation in the form of a carbon fibre sole is also necessary. However, a volume compensation placed loosely in the shoe causes irritation and pressure points at the distal end of the residual limb because the residual limb moves against the toe replacement when walking (shifting).



2. Toe Prostheses with Midfoot Guidance

If all toes are lost, a forefoot replacement with a shaft that extends over the midfoot can be used. Such a toe prosthesis is usually made of silicone and enables a tight and optimal fit on the residual limb [Schä, p. 161].

However, a toe prosthesis only provides volume compensation, and no functional compensation, in addition to appealing cosmetics. Due to the amputation, the function of the short toe flexors to support the swing phase initiation is lost. This restriction cannot be compensated for by a toe prosthesis, or only to a limited extent.



3. Sub-Ankle Foot Prostheses

Sub-ankle foot prostheses are available in different designs: a basic residual limb socket with a forefoot, an industrially produced silicone prosthesis or the so-called Bellmann prosthesis. A secure fit on the residual limb is guaranteed either by an increased coefficient of static friction (silicone prosthesis) or the tight fit of a heel cap (Bellmann prosthesis).

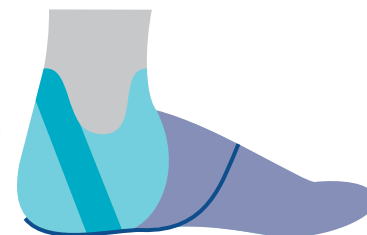

Both options offer good wearing comfort. The anatomical ankle joint remains intact, which only slightly restricts the motion control of the foot [Bau, p. 138]. The attractive cosmetics are an individual advantage of silicone prostheses.

However, the force transmission is severely restricted, especially with a simple residual limb socket, and the forefoot lever is insufficiently restored. Therefore, sub-ankle prostheses are not suitable for high and/or long-lasting loads.

4. Sub-Ankle Foot Prosthesis + Ankle-Foot Orthosis

In order to compensate for the lack of function, especially in the case of short residual limbs, sub-ankle foot prostheses are often combined with custom-made carbon fibre clamshell orthoses [Schä, p. 163] or preproduced ankle-foot frame orthoses [Kai, p. 2; Kai2, p. 19].

A static carbon fibre orthosis does not allow any movement in the anatomical ankle joint. If the orthosis is equipped with a flexible foot piece, shear forces act on the end of the residual limb, causing pressure points. Preproduced ankle-foot orthoses without an ankle joint are not adjustable and thus do not provide an adequate control over plantar flexion and dorsiflexion [Kai, p. 6]. Due to the lack of a defined pivot point in this construction, this can lead to the shifting of the tibial shell on the leg. Rigid preproduced ankle-foot orthoses may cause a hyperextension of the knee joint (genu recurvatum).



5. Clamshell Prosthesis

Clamshell prostheses are individually manufactured for the patient in different designs with closure or access flaps [Schä, p. 163; Kai, p. 2; Kai2, p. 19]. Arthrodesis boots also belong in this orthotic treatment category. All common constructions allow for a good residual limb fit as well as a forefoot lever.

The rigid connection of the lower leg and foot is used to reduce shear forces at the distal end of the residual limb. Depending on the remaining range of motion of the ankle joint, the prosthesis is either produced statically or with some range of motion. The construction with some range of motion does not provide the necessary stability. The static construction blocks the motion in the anatomical ankle joint [Kai, p. 6], which may result in contractures and muscle atrophies.

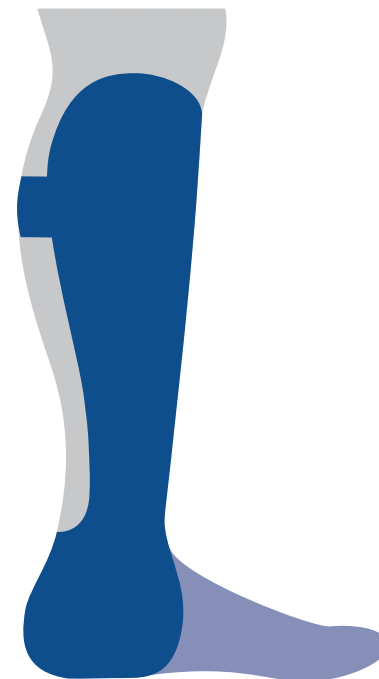

New Possibilities with the NEURO SWING Partial Foot Prosthesis

A dynamic above-ankle component is the optimal complement to a sub-ankle foot prosthesis. The integration of the NEURO SWING system ankle joint enables the stabilisation of the anatomical ankle joint and simultaneously providing range of motion by using a dynamic dorsiflexion stop. Thanks to the adjustability of the spring force and range of motion, it is possible to react to changes of the residual limb. The precompressed spring units allow for an optimal control of the forces that occur during stance and gait.

Precompressed Spring Units

In order to bring a body into a stable balance, the forefoot lever must be activated. Precompressed spring units with a high basic resistance with the NEURO SWING system ankle joint provide dynamic balance and stability. This allows for a secure stance and gait over different terrains.

Since no medical devices other than the NEURO SWING partial foot prosthesis are required, the hands are free for everyday tasks.

In case of a weakness of the plantar flexors, the dynamic activation of the forefoot lever enables a knee-extending moment and guarantees knee stability.

Impacts in Terminal Stance

- heel lift
- body's centre of gravity at physiological height
- normal knee flexion on the contralateral side
- improved energy consumption during walking

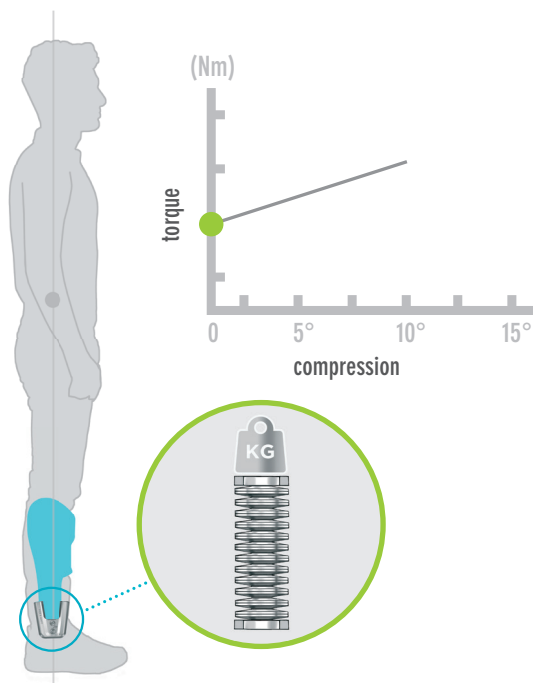

Non-Precompressed Springs

Commonly used standard coil springs must be heavily compressed to generate resistance. The nonexistent basic resistance due to the lack of precompression leads to a yielding of the spring when loaded during stance and, due to the missing security, to an unstable stance and gait. This requires the use of medical devices such as crutches or walkers. The hands are therefore needed for support.

In case of a weakness of the plantar flexors, the activation of the forefoot lever is not possible causing the absence of a knee-extending moment and a reduced knee stability.

Impacts in Terminal Stance

- no heel lift
- body's centre of gravity too low
- excessive knee flexion on the contralateral leg side
- energy consumption during walking too high

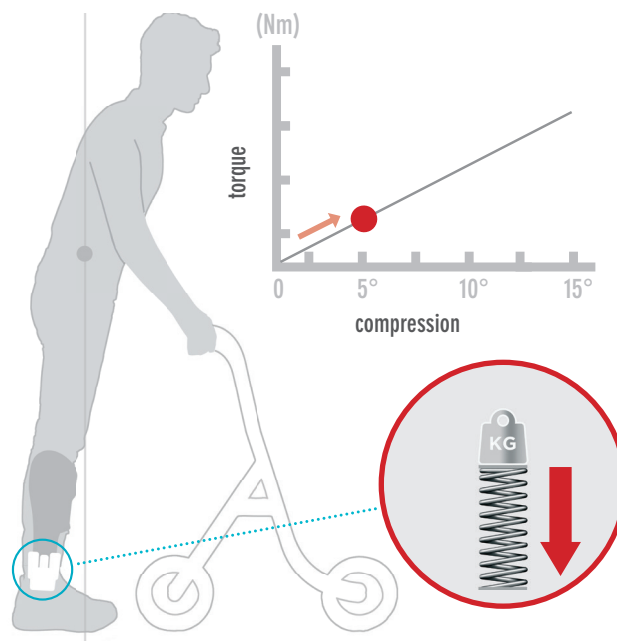

Disadvantages of Current Treatments

Properties of the NEURO SWING

Description

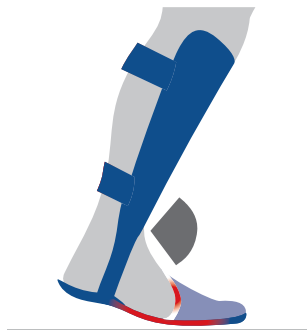

no dynamic dorsiflexion stop

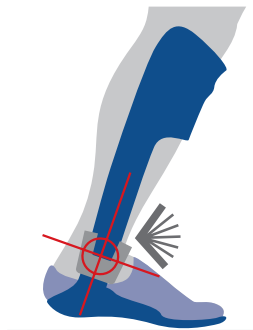

dynamic dorsiflexion stop

To activate the forefoot lever, a dorsiflexion stop is necessary. The NEURO SWING partial foot prosthesis is equipped with a dynamic dorsiflexion stop with a ventral spring unit. This results in a stable yet dynamic balance in stance, a dynamic knee extension in late mid stance and a physiological heel lift in terminal stance. An important prerequisite for this is that the spring units are precompressed. The dynamic dorsiflexion stop prevents a knee hyperextension and shifting of the residual limb in the prosthesis.

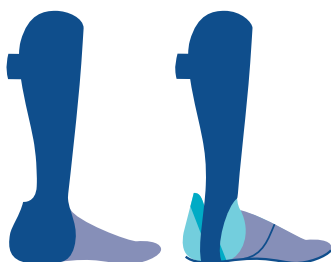

no variable spring force

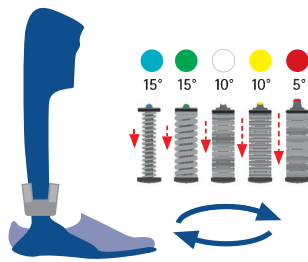

variable spring force

The requirements for a prosthesis can change, sometimes severely, in the course of therapy or due to a residual limb revision. In order to avoid a costly new treatment, the prosthetic treatment should be adaptable if the residual limb changes. With the NEURO SWING partial foot prosthesis, the spring force can be changed by exchanging the dorsal and ventral spring units. There are five spring units with different spring forces ranging from normal to extra strong.

Disadvantages of Current Treatments

Properties of the NEURO SWING

Description



no adjustable alignment

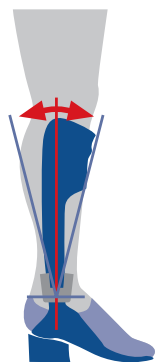

adjustable alignment

In order to achieve a physiological gait, the leverage ratios of the prosthesis must be adjusted to the patient (tuning). Thanks to the adjustable alignment, the prosthetist can also react to a potential increase in the pes equinus position (see chapter *Biomechanical Changes*). The NEURO SWING partial foot prosthesis can also be easily adapted to different heel heights. This makes it easy to change the footwear. In addition, minor positional errors in the model technique can be corrected.

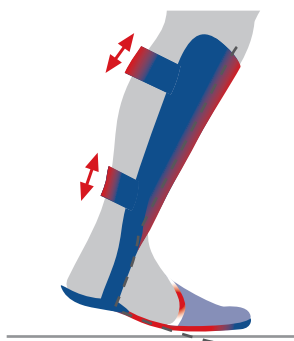

no defined pivot point

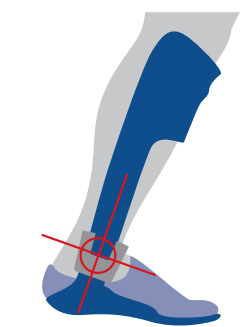

defined pivot point

A defined mechanical pivot point at ankle height plays an important role for the dynamic dorsiflexion stop and thus the activation of the forefoot lever. With the NEURO SWING partial foot prosthesis, the centred rotation prevents the tibial shell from shifting on the leg or the ankle-free foot prosthesis from slipping on the residual limb (shifting) during high and/or prolonged loads. A defined pivot point is also a prerequisite for a passive plantar flexion.

Disadvantages of Current Treatments

Properties of the NEURO SWING

Description

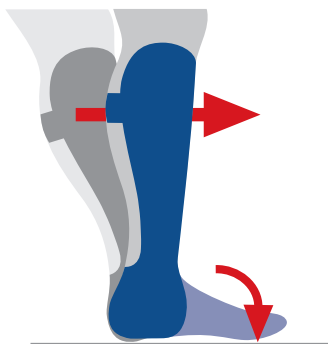

plantar flexion blocked

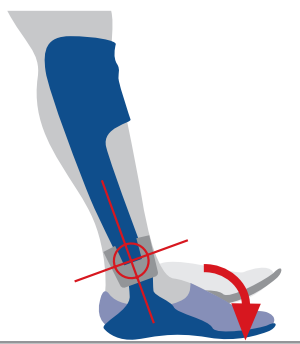

plantar flexion possible

Passive plantar flexion causes the foot to lower and is an important mechanism for shock absorption during load transfer. Thanks to the range of motion in plantar flexion with the NEURO SWING partial foot prosthesis, an excessive torque in the knee can be prevented during loading response. This allows for a physiological quadriceps loading and knee flexion. It also prevents muscle atrophy and contractures.

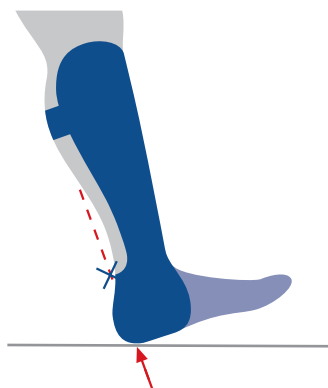

no heel rocker

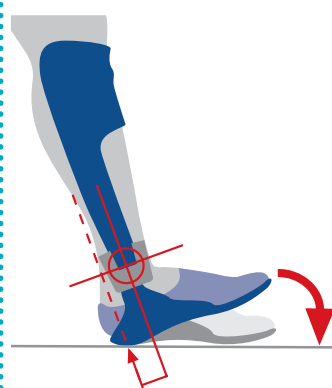

heel rocker

Passive plantar flexion is triggered by the heel lever which runs from the heel strike to the ankle. The dorsal flexors control the heel rocker to prevent an uncontrolled landing of the foot. This muscular control is lost when the dorsal extensors are removed during amputation. The NEURO SWING partial foot prosthesis enables the heel rocker against the resistance of the dorsal spring unit, as there is a defined pivot point and range of motion in plantar flexion. This can counteract the development of contractures and support the approximation to a physiological gait. The resistance of the dorsal spring unit can be precisely adjusted to the muscular control lost due to the amputation.

Disadvantages of Current Treatments

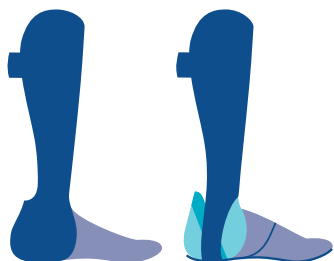

no adjustable range of motion

Properties of the NEURO SWING

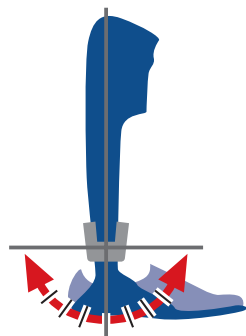

adjustable range of motion

Description

After a surgery or residual limb revision, a temporary immobilisation of the anatomical ankle joint might be necessary in certain cases. With the NEURO SWING partial foot prosthesis, the range of motion can be completely blocked and gradually released again. Thus, a precise adaptation to the range of motion of the anatomical ankle joint after the amputation is possible.

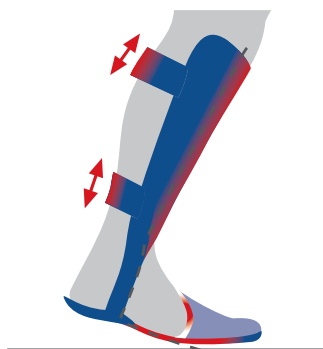

occurrence of shear forces

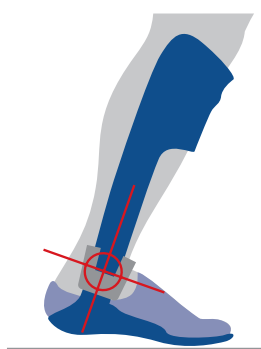

reduction of shear forces

To ensure that the sensitive residual limb is optimally protected in the prosthesis, shear forces must be avoided as much as possible. This requirement must be taken into account especially in the prosthetic treatment of diabetics, as many of these patients cannot perceive stimuli. The defined pivot point and the dynamic dorsiflexion stop of the NEURO SWING partial foot prosthesis prevent so-called shifting, which leads to shear forces on the residual limb. Similarly, dangerous pressure peaks on the residual limb can be minimised by the targeted and individual design of the foot piece.

Partial foot amputations significantly influence the biomechanics of stance and gait. The degree of the restriction depends on the amputation level and the resulting loss of muscular and bony structures. This loss results in a functional shortening of the forefoot lever, a change of the muscular balance between plantar flexors and dorsal flexors, and a reduction of the muscle strength of the muscle groups involved during stance and gait.

Loss of Bony Structures

The skeleton of the foot forms a support surface and thus the static basis for stance and gait. During a physiological stance, the load is distributed on the heel and the ball of the big toe and the ball of the little toe. When walking, the toes also represent an essential part of the support surface for the body's centre of gravity. After a partial foot amputation, the bony structures of the distal end of the residual limb limit this support surface. The shorter the residual limb, the smaller the support surface in the one- and two-legged stance [Bau, p. 135].

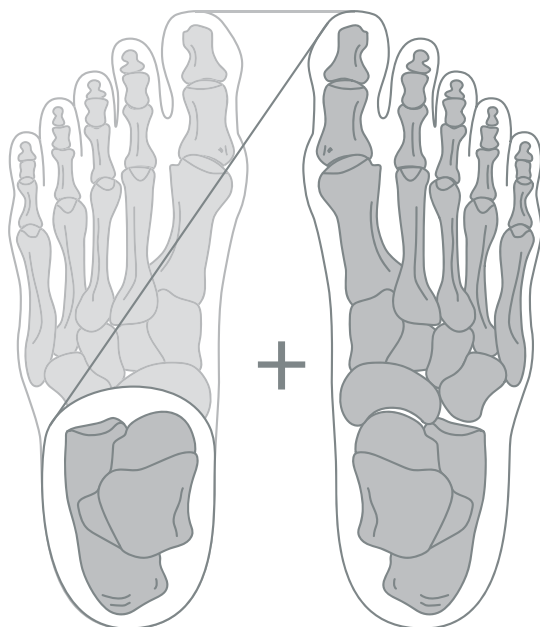

+ body's centre of gravity

Structural Shortening of the Forefoot Lever

In the sagittal plane, as the residual limb length decreases, the calcaneal angle (2) and thus also the longitudinal arches of the foot flattens, resulting in an increasing equinus position and a functional shortening of the leg length. The loss of bony structures significantly contributes to the structural shortening of the forefoot lever (1).

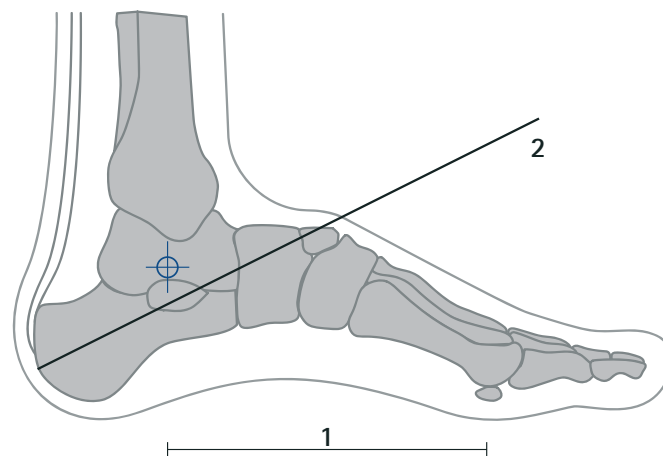

Loss of Muscular Structures

With a partial foot amputation, the long foot muscles remain intact. During the course of the surgery, the short plantar foot muscles and the plantar fascia are used for soft tissue coverage when closing the end of the residual limb. As both the short foot muscles and the plantar fascia stabilise the medial longitudinal arches of the foot, the flattening of the calcaneal angle caused by the loss of the bony structures is reinforced. The loss of muscular structures significantly affects a safe stance and gait in two ways:

- change of the muscular balance
- reduction of muscle strength

Change in Muscular Balance

The long foot muscles affected by the amputation lose their attachment to the bone, resulting in a muscular imbalance. The m. triceps surae exerts a strong pull on the residual limb via the achilles tendon, which leads to the development of an equinus deformity (pes equinus). The more proximal the amputation, the more dorsal flexors that control this pull lose their attachment. This imbalance is particularly evident in Bona-Jäger or Chopart amputations due to the loss of the m. tibialis anterior (see figure). Due to this plantar flexed residual limb position, the range of motion of the upper ankle joint is severely limited, which can result in contractures. If the residual limb is held in slight dorsiflexion during the making of the negative cast, at least a functional range of motion is possible.

Reduction of Muscle Strength

The removal of the long and the short foot muscles associated with amputation results in a reduced muscle strength of the dorsal flexors and plantar flexors [Dil2, p. 1328]. Both muscle groups are relevant to the physiological stance and gait. For example, the plantar flexors ensure the activation of the forefoot lever, while the dorsal flexors ensure the foot lifting during swing phase. The extent of this reduction depends on how many muscles are still functional.

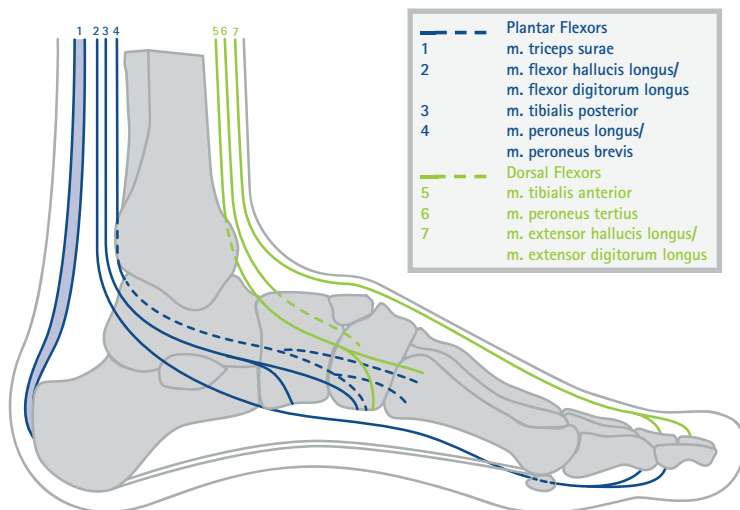

Functional Shortening of the Forefoot Lever

The biomechanics of stance and gait are largely determined by the effects of the anatomical pivot point (P) of the upper ankle joint in interaction with the forefoot lever (f) and rear foot lever (r).

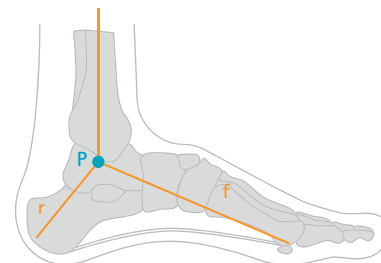

Biomechanical restrictions during stance and gait in patients with partial foot amputations are primarily due to the shortening of the forefoot lever. If there is no amputation, the forefoot lever is activated by the plantar flexors and allows for an energy-efficient stance and gait. During gait, a physiological heel lift, knee extension and raise of the body's centre of gravity in terminal stance takes place. The goal of a prosthetic treatment is to compensate for the loss of bony and muscular structures caused by the amputation. The basis for this is the replacement of the removed bony structures with a mechanical forefoot lever. If the physiological activation by the plantar flexors is no longer possible without restrictions, the forefoot lever must also be activated mechanically.

The forefoot lever can be activated via a mechanical connection to the forefoot lever without joints, as in classical orthopedics (1). However, in order to enhance and maintain the mobility of the upper ankle joint, the activation should preferably take place via a mechanical joint (2) with a static (2a) or, even better, a dynamic dorsiflexion stop (2b).

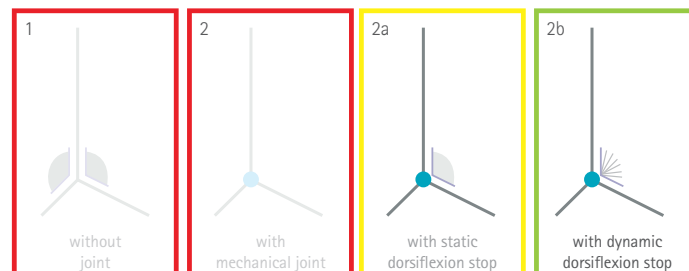







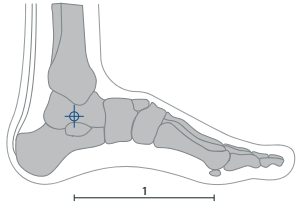

1 not recommended 2 recommended with restrictions 2a recommended 2b recommended

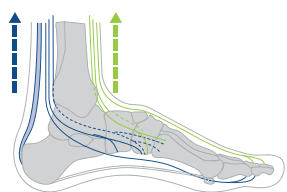
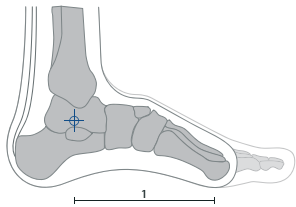
In order to optimally adapt the prosthetic treatment to the patient, the individual condition of the muscles and foot bones must be taken into account. To structure and systematise prosthetic treatments, the various amputations are assigned to types in which the requirements for a prosthetic treatment are the same.

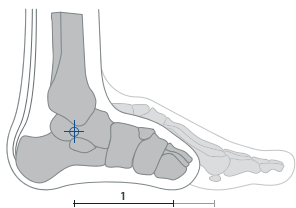
The classification takes the length of the forefoot lever, the muscular balance between plantar flexors (PF) and dorsal flexors (DF), and the muscle strength of the DF into account.

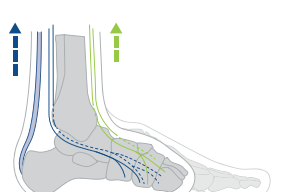
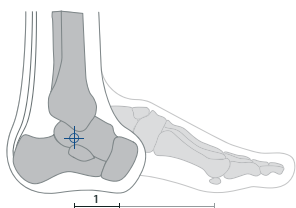
Example: in type 1, the attachments of the short and long toe flexors and extensors are no longer there, which is why the muscle strength of the DF is restricted despite the muscular balance.

Type	Amputation	Forefoot Lever	Muscular Imbalance	Distribution of Force
	not amputated	 long	 balanced	 full muscle strength
1	metatarsophalangeal transmetatarsal (Sharp)	 long	 balanced	 limited muscle strength
2	transmetatarsal (Sharp-Jäger) tarsometatarsal (Lisfranc)	 medium	 plantar flexors (PF) dominate	 low muscle strength
3	transtarsal (Bona-Jäger) transtarsal (Chopart)	 short	 plantar flexors (PF) dominate	 no muscle strength

Biomechanical Changes

Type 1 includes residual limbs after a toe exarticulation, ray resection or amputation in the metaphyseal area at the midfoot heads (Sharp).

The forefoot lever remains relatively long (1). The support surface is hardly reduced during stance and in the stance phase when walking. The calcaneal angle is minimally flattened, which is why the residual limb only deviates into a very slight equinus position (2) and leg length discrepancy.

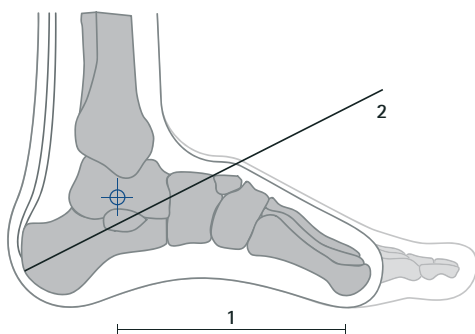

The bases of the short and long toe flexors are no longer there. The deactivation of these muscle groups leads to a loss of passive pretension in pre swing, which eliminates the support of the push off to initiate swing phase [For, p. 42f].

The muscular balance between dorsal flexors and plantar flexors is even. The muscle strength of both muscle groups is mostly normal [Dil2, p. 1328].

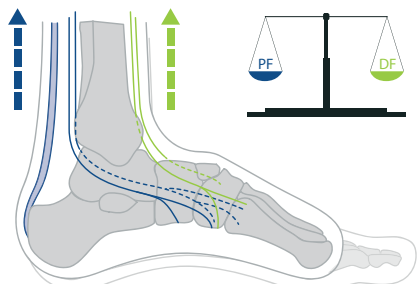

NEURO SWING Partial Foot Prosthesis

Consisting of:

- high ventral tibial shell,
- foot piece with residual limb socket,
- NEURO SWING system ankle joint.

High Ventral Tibial Shell

The high ventral tibial shell rests against the tibia. This allows the patient to apply their body weight directly to the NEURO SWING partial foot prosthesis, similar to a downhill ski boot. This feature enables the immediate activation of the forefoot lever using the dynamic dorsiflexion stop.

Foot Piece with Residual Limb Socket

In order for the patient to be able to perform the heel-to-toe movement as physiologically as possible, a long partially flexible foot piece (rigid sole with flexible toe area) is recommended.

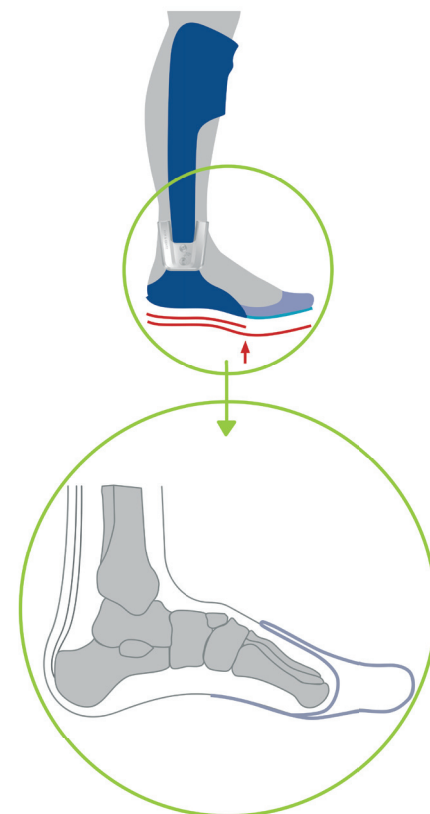

The residual limb socket is an integral part of the NEURO SWING partial foot prosthesis and can either be produced as a toe prosthesis or be permanently connected to the foot piece. In order to optimally pad the skin and soft tissue on the residual limb, it must be protected from pressure and shear forces. In addition to padding the end of the residual limb, the socket also serves as a toe replacement.

NEURO SWING System Ankle Joint

Spring units to be used:

- dorsal: blue marking (normal spring force, max. 15° range of motion);
- ventral: green marking (medium spring force, max. 15° range of motion).

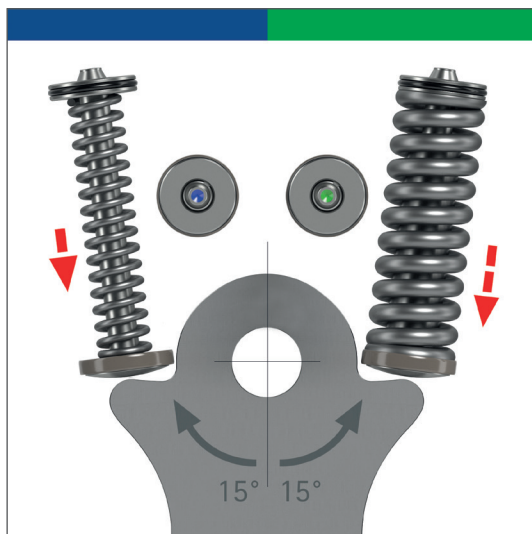

■ dorsal (spring unit) ■ ventral (spring unit)

Individual adaptation to the partial foot prosthesis by:

- interchangeable, precompressed spring units,
- adjustable alignment,
- adjustable range of motion.

All three adjustment options can be chosen separately. They do not influence each other.

Mode of Action of the NEURO SWING Partial Foot Prosthesis

Stance

The dynamic dorsiflexion stop activates the mechanical forefoot lever and thus establishes the physiological support surface and a stable balance. The green spring unit of the NEURO SWING system ankle joint is precompressed and thus already generates the torque for a sufficiently high basic resistance during stance (see info box).

Gait

Between mid stance and terminal stance, the forward motion of the tibia directs energy into the green ventral spring unit. The dynamic dorsiflexion stop enables the heel to detach leading to a physiological stride length.

In pre swing, this energy is released and, combined with the partially flexible foot piece, supports the knee flexion during the swing phase initiation. The green spring unit's range of motion of 15° in dorsiflexion direction promotes the stretching of the long plantar flexors.

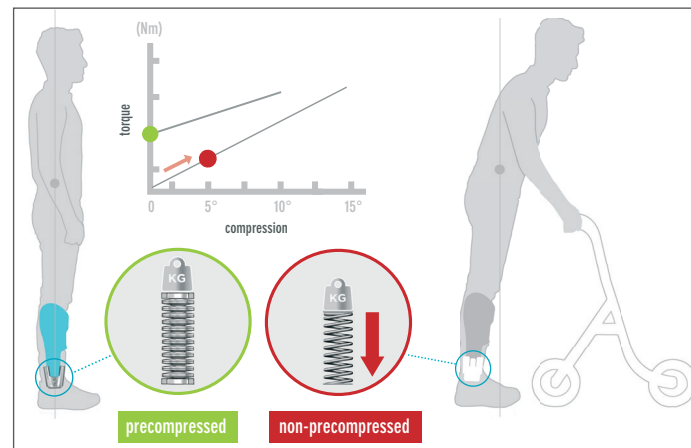

Current Treatment Options

Patients of this type have often been treated with a simple toe filler for the shoe. This involves loosely placing the toe replacement in the shoe or attaching it to an insole. A functional compensation does not exist.

Such a treatment is disadvantageous in that a volume compensation without the necessary padding exerts a high pressure on the end of the residual limb in the shoe during walking. This pressure is caused by the end of the residual limb moving against the volume compensation. In addition, no adequate functional compensation is provided for the lack of knee flexion during the swing phase initiation.

Note on the Treatment of Diabetics

Especially in patients with amputations due to the diabetic foot syndrome, increased attention is required to avoid pressure peaks on the residual limb. The immobilisation of the residual limb is achieved by means of a rigid sole, which can either be integrated into the shoe or directly into the NEURO SWING partial foot prosthesis.

Shoe

A shoe for a NEURO SWING partial foot prosthesis must, among others, meet the following requirements:

- inner volume with sufficient space for the NEURO SWING system ankle joint
- rigid heel cap for high stability of the NEURO SWING partial foot prosthesis in the shoe
- slip-resistant outsole

The orthosis shoes URBANSTREET, PARKSTREET and CROSSROADS from FIOR & GENTZ meet these requirements (the picture below shows the CROSSROADS orthosis shoe in black).



Biomechanical Changes

Type 2 includes residual limbs after an amputation in the metaphyseal area at the bases of the metatarsal bone (Sharp-Jäger) and residual limbs after a tarsometatarsal amputation (Lisfranc).

The forefoot lever has a medium length (1) and the support surface is reduced, resulting in restrictions in stance and gait. The flattening of the calcaneal angle (2) causes an equinus position and a small leg length discrepancy.

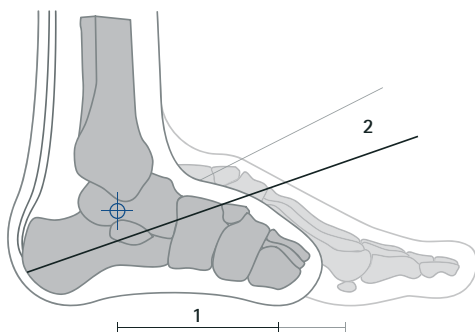

In the case of a complete removal of the metatarsals bone (Lisfranc), the branch of the m. tibialis anterior attached to the upper base of the first metatarsal bone is removed. Thus, in addition to the limitations described for type 1, the control of the plantar flexion and supination caused by the m. triceps suraemuscle decreases.

There is a muscular imbalance between dorsal flexors and plantar flexors in favor of the plantar flexors. The muscle strength, especially of the dorsal flexors, is greatly decreased [Dil2, p. 1328].

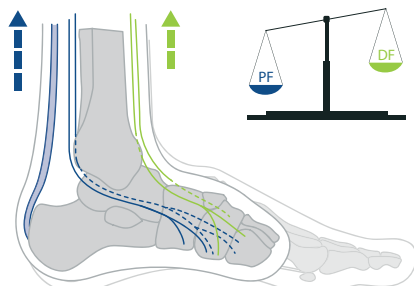

NEURO SWING Partial Foot Prosthesis

Consisting of:

- high ventral tibial shell,
- foot piece with residual limb socket,
- NEURO SWING system ankle joint.

High Ventral Tibial Shell

The high ventral tibial shell rests against the tibia. This allows the patient to apply their body weight directly to the NEURO SWING partial foot prosthesis, similar to a downhill ski boot. This feature enables the immediate activation of the forefoot lever using the dynamic dorsiflexion stop.

Foot Piece with Residual Limb Socket

In order for the patient to be able to perform the heel-to-toe movement as physiologically as possible, a long partially flexible foot piece (rigid sole with flexible toe area) is recommended.

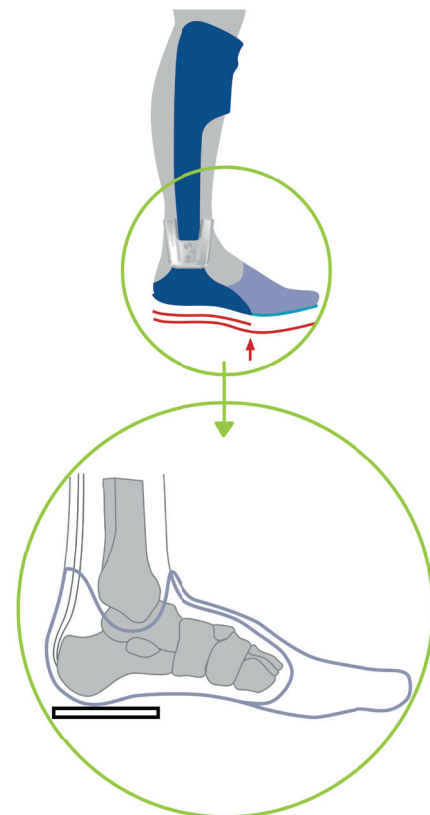

The residual limb socket is an integral part of the NEURO SWING partial foot prosthesis and can either be produced as an ankle foot prosthesis or be permanently connected to the foot piece. In order to optimally pad the skin and soft tissue on the residual limb, it must be protected from pressure and shear forces. In addition to padding the end of the residual limb, the socket also serves as a forefoot replacement. The small leg length discrepancy is compensated by in the residual limb socket.

NEURO SWING System Ankle Joint

Spring units to be used:

- dorsal: blue marking (normal spring force, max. 15° range of motion);
- ventral: yellow marking (very strong spring force, max. 10° range of motion).

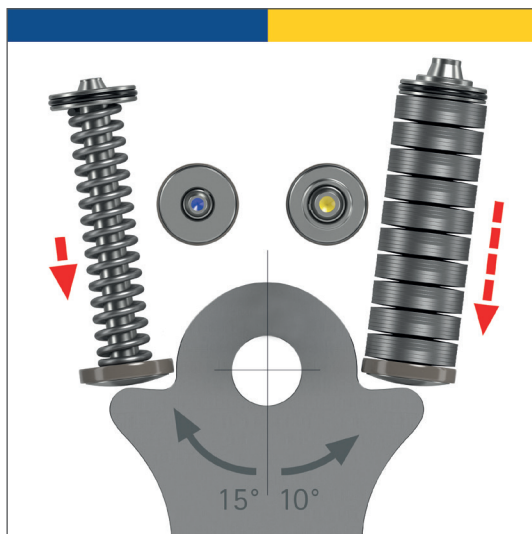

■ dorsal (spring unit) ■ ventral (spring unit)

Individual adjustment to the partial foot prosthetic by:

- interchangeable, precompressed spring units,
- adjustable alignment
- adjustable range of motion.

All three adjustment options can be chosen separately. They do not influence each other.

Mode of Action of the NEURO SWING Partial Foot Prosthesis

Stance

The dynamic dorsiflexion stop activates the mechanical forefoot lever and thus establishes the physiological support surface and a stable balance. The yellow spring unit of the NEURO SWING system ankle joint is precompressed and thus already generates the torque for a sufficiently high basic resistance during stance (see info box).

Gait

In mid stance, the long partially flexible foot piece restores the forefoot lever, which is activated by the very strong yellow spring unit of the NEURO SWING system ankle joint. The dynamic dorsiflexion stop enables stable balance and controlled forward motion of the tibia during late mid stance, contributing to an optimal knee stability.

In terminal stance, the dynamic dorsiflexion stop provides mobility via the defined mechanical pivot point of the joint in dorsal extension direction, stretching the plantar flexors. The basic resistance generated by the precompressed spring units allows the heel to detach leading to a physiological stride length. By stretching the plantar flexors, the swing phase initiation is supported during pre swing.

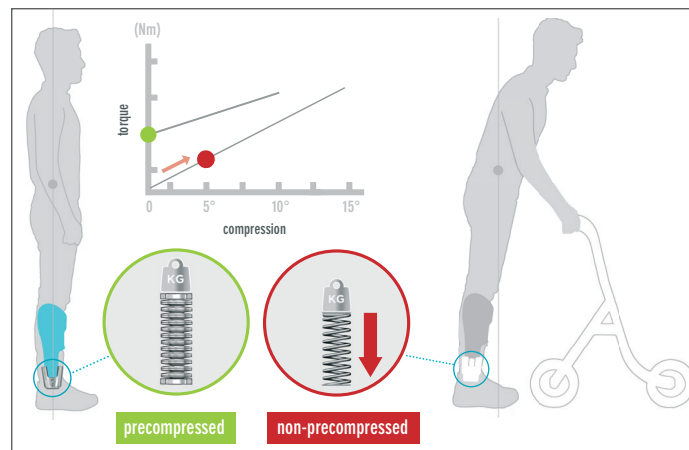

Current Treatment Options

Patients of this type have often been treated with a sub-ankle foot prostheses (forefoot prosthesis according to Bellmann or silicone forefoot prosthesis) or residual limb sockets with a forefoot replacement and ankle-foot orthoses.

With sub-ankle foot prostheses, the forefoot lever can only be activated to a limited extent, despite good adhesion to the foot (heel grip with Bellmann; static friction with silicone). The prosthesis may shift during high or prolonged loads if the forefoot is loaded during terminal swing and pre swing.

The insufficient functional compensation of a simple residual limb socket should be compensated for by stabilisation with a clamshell orthosis or a preproduced ankle-foot orthosis. However, most clamshell orthoses do not allow any motion in the anatomical ankle joint and thus do not help to achieve a physiological gait. In contrast, many preproduced ankle-foot orthoses are not stable enough to restore the forefoot lever [Kai, p. 6]. In addition, they cause the orthosis shells to shift on the leg since they do not have a defined pivot point. The resulting shear forces in the foot piece exert great pressure on the sensitive end of the residual limb.

Note on the Treatment of Diabetics

Especially in patients with amputations due to the diabetic foot syndrome, increased attention is required to avoid pressure peaks on the residual limb. The immobilisation of the residual limb is achieved by means of a rigid sole, which can either be integrated into the shoe or directly into the NEURO SWING partial foot prosthesis.

Shoe

A shoe for a NEURO SWING partial foot prosthesis must, among others, meet the following requirements:

- inner volume with sufficient space for the NEURO SWING system ankle joint
- rigid heel cap for high stability of the NEURO SWING partial foot prosthesis in the shoe
- slip-resistant outsole that can be shaped to compensate for the height difference due to the equinus position

The orthosis shoes URBANSTREET, PARKSTREET and CROSSROADS from FIOR & GENTZ meet these requirements (the picture below shows the CROSSROADS orthosis shoe in black).



Biomechanical Changes

Type 3 includes residual limbs after a transtarsal amputation (Bona-Jäger or Chopart).

The forefoot lever is short (1) and the support surface is greatly reduced, which leads to considerable restrictions during stance and gait. Due to the flattening of the calcaneal angle (2), a pronounced equinus position and a leg length discrepancy is developed.

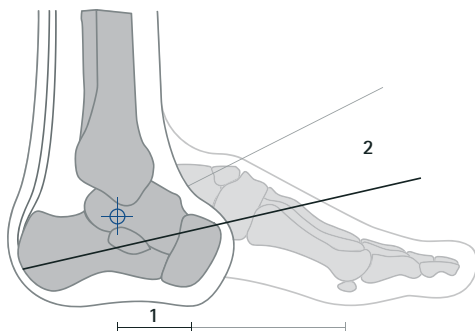

With this type, the last branches of the m. tibialis anterior and the m. peroneus tertius are removed, which leaves no muscles able to control the plantar flexion and supination of the m. triceps surae. Due to the prominent plantar flexion position of the residual limb and a lack of range of motion in the upper ankle joint, there is a risk of the development of painful contractures.

There is a muscular imbalance between dorsal flexors and plantar flexors, with a strong dominance of plantar flexors.

The dorsal flexors cannot develop any motion-related force [DiI2, p. 1328].

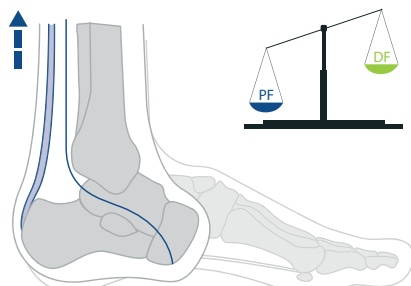

NEURO SWING Partial Foot Prosthesis

Consisting of:

- high ventral tibial shell,
- foot piece with residual limb socket,
- NEURO SWING system ankle joint.

High Ventral Tibial Shell

The high ventral tibial shell rests against the tibia. This allows the patient to apply their body weight directly to the NEURO SWING partial foot prosthesis, similar to a downhill ski boot. This feature enables the immediate activation of the forefoot lever using the dynamic dorsiflexion stop.

Foot Piece with Residual Limb Socket

In order for the patient to be able to perform the heel-to-toe movement as physiologically as possible, a long partially flexible foot piece (rigid sole with flexible toe area) is recommended.

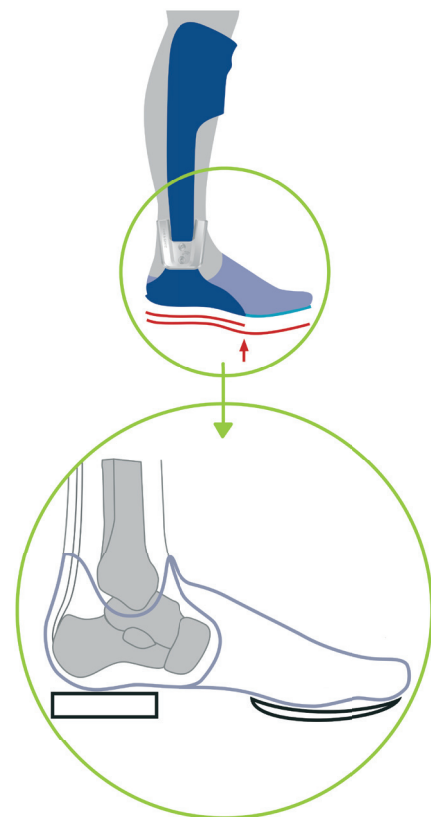

The residual limb socket is an integral part of the NEURO SWING partial foot prosthesis and can either be produced as a sub ankle foot prosthesis or firmly connected to the foot piece. In order to optimally bed the skin and soft tissue on the residual limb of the foot, the residual limb must be protected from pressure and shear forces. In addition to padding the end of the residual limb, the socket also serves as a midfoot and forefoot replacement. The leg length discrepancy is compensated by in the residual limb socket/or in the shoe.

NEURO SWING System Ankle Joint

Spring units to be used:

- dorsal: green marking (medium spring force, max. 15° range of motion);
- ventral: red marking (extra strong spring force, max. 5° range of motion).

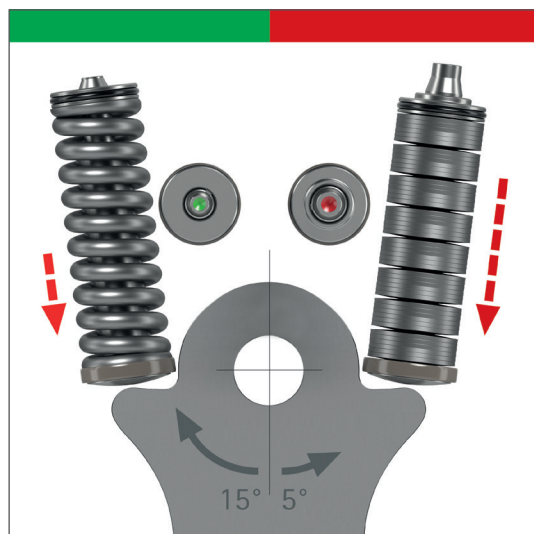

■ dorsal (spring unit) ■ ventral (spring unit)

Individual adjustment to the partial foot prosthetic by:

- interchangeable, precompressed spring units,
- adjustable alignment
- adjustable range of motion.

All three adjustment options can be chosen separately. They do not influence each other.

Mode of Action of the NEURO SWING Partial Foot Prosthesis

Stance

The dynamic dorsiflexion stop activates the mechanical forefoot lever and thus establishes the physiological support surface and a stable balance. The red spring unit of the NEURO SWING system ankle joint is precompressed and thus already generates the torque for a sufficiently high basic resistance during stance (see info box).

Gait

In mid stance, the long partially flexible foot piece restores the forefoot lever, which is activated by the very strong red spring unit of the NEURO SWING system ankle joint. The dynamic dorsiflexion stop enables a stable balance and controlled forward motion of the tibia in late mid stance, contributing to optimal knee stability.

In terminal stance, the dynamic dorsiflexion stop provides mobility over the defined mechanical joint pivot point in the dorsal extension direction, stretching the plantar flexors. The basic resistance generated by the precompressed spring units allows the heel to detach leading to a physiological stride length. By stretching the plantar flexors, the swing phase initiation is supported during pre swing.

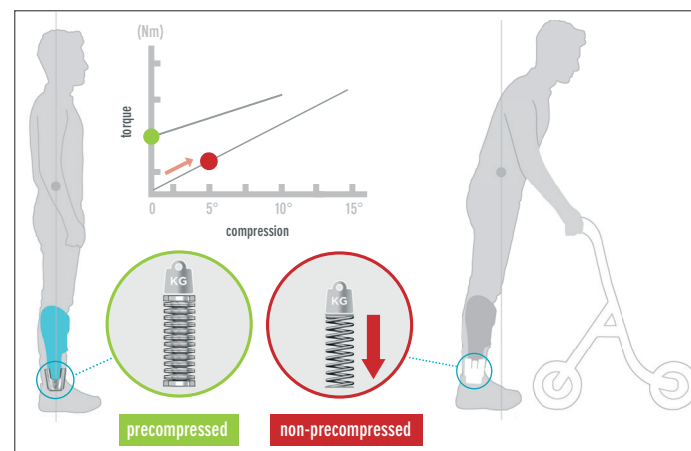

Current Treatment Options

Patients of this type have often been treated with above-ankle clamshell prostheses or sub-ankle foot prostheses (forefoot prosthesis according to Bellmann or silicone forefoot prosthesis).

However, sub-ankle foot prostheses do not provide patients with sufficient stability and only provide insufficient functional compensation. Therefore, these treatments are supplemented by ankle-foot orthoses (carbon fibre clamshell orthoses or preproduced ankle-foot orthoses).

However, most clamshell prostheses above the ankle do not allow any movement in the anatomical ankle joint and do not help achieve a physiological gait.

In contrast, many preproduced ankle-foot orthoses are not stable enough to restore the forefoot lever [Kai, p. 6]. In addition, they cause the orthosis shells to shift on the leg since they do not have a defined pivot point. The resulting shear forces in the foot part exert great pressure on the sensitive end of the residual limb.

Note on the Treatment of Diabetics

Especially in patients with amputations due to the diabetic foot syndrome, increased attention is required to avoid pressure peaks on the residual limb. The immobilisation of the residual limb is achieved by means of a rigid sole, which can either be integrated into the shoe or directly into the NEURO SWING partial foot prosthesis.

Shoe

A shoe for a NEURO SWING partial foot prosthesis must, among others, meet the following requirements:

- inner volume with sufficient space for the NEURO SWING system ankle joint
- rigid heel cap for high stability of the NEURO SWING partial foot prosthesis in the shoe
- slip-resistant outsole that can be shaped to compensate for the height difference due to the equinus position

The orthosis shoes URBANSTREET, PARKSTREET and CROSSROADS from FIOR & GENTZ meet these requirements (the picture below shows the CROSSROADS orthosis shoe in black).



A prosthesis must be optimally adapted to the pathological gait to establish the best possible biomechanical situation. With the NEURO SWING system ankle joint, this goal is achieved through interchangeable spring units, an adjustable alignment and an adjustable range of motion.

Effects on the Gait during Initial Contact and Loading Response

Due to the interchangeable spring units of the NEURO SWING system ankle joint, the spring force can be optimally adapted to the pathological gait. Finding the right spring force is an optimisation process which requires careful consideration of the different functionalities. Nevertheless, the fact that adjustments are an option is a great advantage for the individualisation of prostheses.

The NEURO SWING system ankle joint enables a passive plantar flexion as well as a physiological heel rocker by means of the defined pivot point and the adjustable range of motion. The range of plantar flexion depends on the chosen spring unit. The lowering of the foot is controlled by the dorsal spring unit. In combination with a range of motion of 15°, a normal spring force (blue spring unit) enables the largest heel rocker. The passive plantar flexion is controlled by the eccentric work of the m. tibialis anterior.

The extent of this eccentric work and therefore the level of the motor impulses are influenced by the spring force and the range of motion.

Since the range of the heel rocker and the passive plantar flexion decreases with increasing spring force, a proportionately greater flexion moment is applied to the knee. This results in a faster tibial progression and a higher load on the m. quadriceps. Increasing the resistance against plantar flexion results in an increasing knee flexion between loading response and early mid stance as well as a smaller maximum plantar flexion [Kob, p. 458].

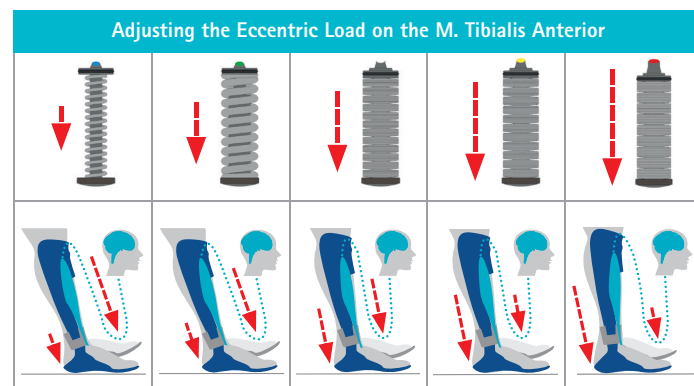

The lower the spring force, the greater the eccentric load on the m. tibialis anterior will be.

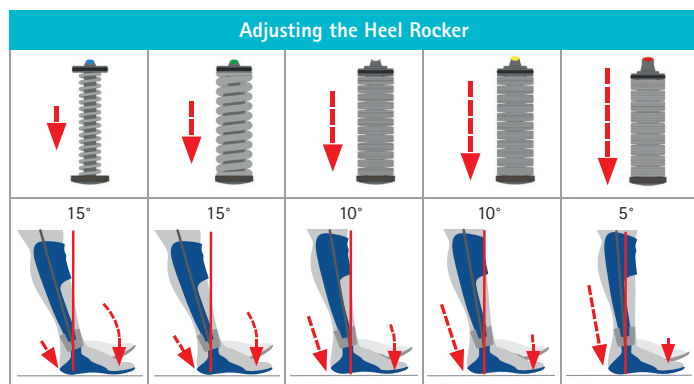

The lower the spring force, the larger the heel rocker will be.

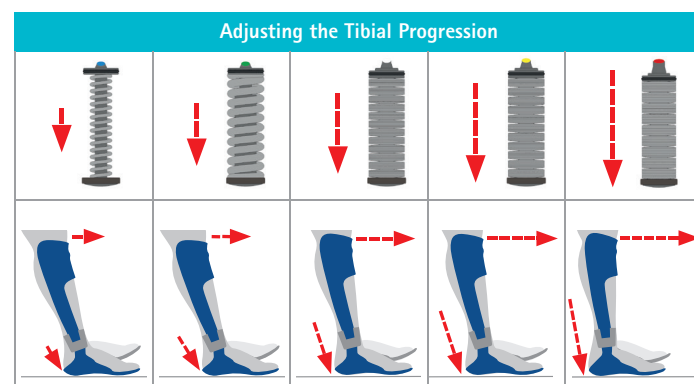

The higher the spring force, the greater the tibial progression will be.

Effects on the Gait during Mid Stance

In mid stance, the forward motion of the lower leg is performed against the resistance of the ventral spring unit. A red spring unit with extra strong spring force causes the highest resistance. The applied energy is stored in the disc springs. The movement in the ankle joint is limited by the range of motion of the chosen spring unit (5°–15°). In order to take full advantage of the adjustable alignment of the prosthesis during this gait phase, it is recommended to calculate a tibial tilt of 10°–12°. Optimum leverage ratios exist at this inclination [Owe, p. 257]. This adjustment of the prosthesis' alignment can be made directly at the joint.

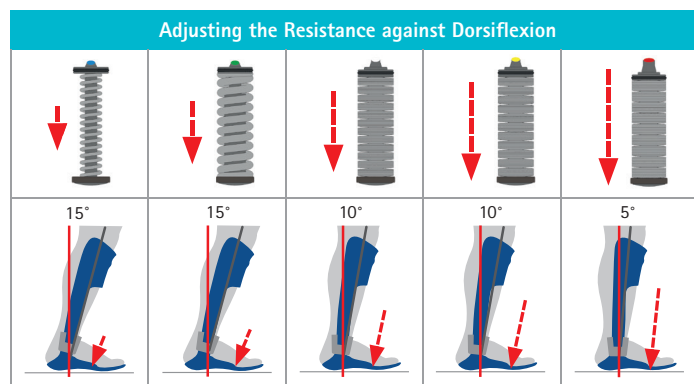

The higher the spring force, the greater the resistance against dorsiflexion will be.

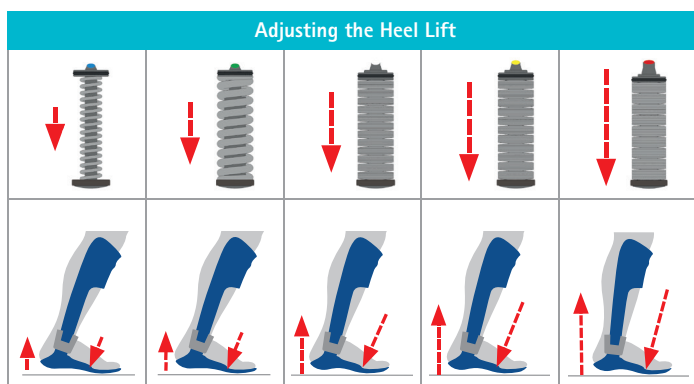

The higher the spring force, the sooner the heel will lift.

Effects on the Gait during Terminal Stance

Between late mid stance and terminal stance, the compressed ventral spring unit causes the heel to lift from the ground. With a very high spring force and a range of motion of 5°, the heel lifts earlier than with a normal spring force and a range of motion of 15°.

Effects on the Gait during Pre Swing

The energy stored in the ventral spring unit is released during pre swing. Since the extra strong spring unit can store the most energy, it also supports the push off of the leg the most. In an AFO with strong spring forces and a defined range of motion, the push off can support an approximation towards a physiological gait during pre swing [Des, p. 150]. The spring units with the largest range of motion also cause the foot to take the longest way back into a neutral position.

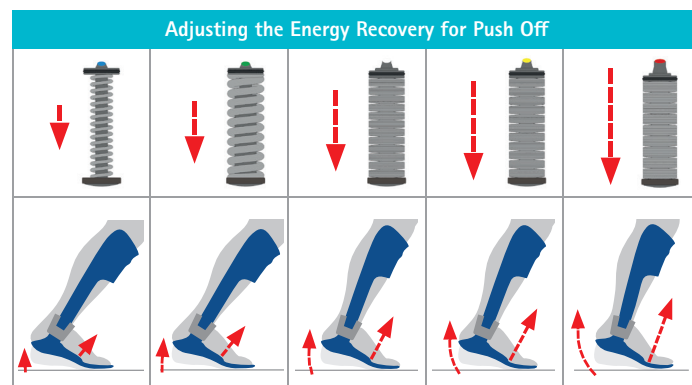

The higher the spring force, the more energy will be recovered for push off.

Effects on the Gait during Swing Phase

The strength of each of the five spring units of the NEURO SWING system ankle joint is sufficient to keep the foot in a neutral position or slight dorsiflexion, thus ensuring that the heel touches the ground at initial contact. This position is the most important prerequisite for a heel rocker and a physiological loading response [Nol, p. 659].

Amputation

Surgical or traumatic separation of a body part. A major amputation involves an amputation at the lower or upper leg. The ankle joint is then removed. With a minor amputation, the ankle joint remains intact.

Arthrodesis Boot

An arthrodesis boot blocks the motion in the ankle joint completely. In addition to the stabilising cap, a support strap and a rocker bottom sole are incorporated into the boot, which is why an arthrodesis boot is also called a fixed rolling-off boot.

Bellmann Prosthesis

An ankle-free foot prosthesis developed by the Swiss prosthetist Dieter Bellmann. It is handmade and consists of a flexible shaft, a carbon rolling-off line and a forefoot replacement made of foam. The hold on the foot is achieved by a heel frame with a bandage strap.

(Carbon) Clamshell Orthosis/Prosthesis

Medical device made of carbon covering the ankle. The foot piece is connected to the ↑ventral tibia shell on the ↑medial and ↑lateral sides. The patient steps into the orthosis or prosthesis from the ↑dorsal side as if through a frame.

Contracture

(from Latin *contrahere* = to tighten): tissue shortening or shrinking, e.g. of certain muscles or tendons. This leads to a reversible or irreversible mobility restriction or fixed deformity of the adjoining joints. There are elastic and rigid contractures.

Contraindication

(from Latin *contra* = against, contrary to, lat. *indicare* = display): circumstance that prohibits the use or continued use of a particular medication or therapeutic measure that is appropriate in itself

Cosmetic

In prosthetics, cosmetics is the design of a prosthesis or a prosthesis covering that is visually adapted to the body.

Distal

(from Latin *distare* = to be distant): denoting a position away from the centre of the body. The opposite of distal is ↑proximal.

Dorsal

(from Latin *dorsum* = back): belonging to the back, located at the back. If, for example, an ankle-foot orthosis is produced with a dorsal shell, the shell is placed against the back of the lower leg, i.e. the calf.

Dorsiflexion Stop

Constructional element of an orthosis that limits the degree of ↑dorsiflexion. The dorsiflexion stop activates the ↑forefoot lever, thereby creating an area of support. Furthermore, a dorsiflexion stop causes, together with the orthosis' foot piece, a knee extension moment and a heel lift starting at terminal stance.

Dorsiflexion

Lifting of the foot. The countermovement of ↑plantar flexion. Referred to as a ↑flexion motion because it reduces the angle between the lower leg and the foot. Functionally, however, it is a stretching movement in the sense of an extension. Muscles which perform this movement are called dorsal flexors.

Dynamic

(from Greek *dynamikos* = active, strong): displaying movement, characterised by momentum and energy

End Contact

Full contact of a residual limb with the enclosing shaft

Equinus

Fixation of the foot in ↑plantar flexion causing the heel to lift. Since the heel does not touch the ground when walking, the equinus is also called drop foot (*pes equinus*).

Exarticulation

Amputation of a limb through a joint. The ↑proximal bones remain completely intact. A toe exarticulation refers to the amputation of a ↑ray in which the base joint of the toe is severed.

Forefoot Lever

anatomical lever arm running from the upper ankle joint to the metatarsophalangeal joints of the toes

Heel Frame

fixation of the heel by the constructive element of a prosthetic shaft

Heel Lever

A lever, which uses the ↑ point of heel strike as the pivot point and the distance of the point of heel strike to the anatomical ankle joint as the lever arm. At initial contact, the ground reaction force running ↑ dorsally from the ankle causes a rotation around the point of heel strike.

Heel Rocker

Involves the complete rotation of the foot around the ↑ point of heel strike. It occurs in the anatomical ankle joint between initial contact and loading response: from terminal swing to initial contact, the swing leg "drops" to the ground from a height of about 1cm. The ground reaction force becomes effective at the point of heel strike. Its force vector (broken line) runs dorsally from the ankle. The resulting ↑ heel lever creates a plantar flexion moment in the ankle, which lowers the foot. The ↑ m. tibialis anterior works eccentrically against this movement, thus allowing a controlled foot dropping.

Interdisciplinary

(from Latin *inter* = between): concerning the cooperation between several fields; cross-disciplinary

Lateral

(from Latin *latus* = flank, side): laterally, facing away from the centre of the body

Medial

(from Latin *medius* = the one in the middle): middle, oriented towards the center of the body, positioned towards the center

Metaphysis

(from Greek *meta* = between, amid; *physis* = nature): section of the long bones between the bone shaft (diaphysis) and the joint-forming end (epiphysis), which consists of spongy bone substance (spongiosa)

Metatarsophalangeal Joints

joints between the midfoot bone (ossa metatarsalia) and the proximal phalanges (phalanges proximales)

M. Quadriceps

Musculus quadriceps femoris: four-headed muscle of the femur. The largest muscle in the body. It causes the extension of the lower leg in the knee joint. It consists of the following submuscles: musculus rectus femoris, musculus vastus medialis, musculus vastus lateralis and musculus vastus intermedius.

M. Tibialis Anterior

Musculus tibialis anterior: anterior tibial muscle. A muscle running from the tibia to the medial edge of the foot, which causes the ↑ dorsiflexion of the foot.

M. Tibialis Surae

Musculus triceps surae: three-headed calf muscle. Summarising term for the two-headed ↑ gastrocnemius muscle and the ↑ soleus muscle.

Muscle Atrophy

(from Greek *atrophia* = depletion, weakening): visible decrease in the circumference of a skeletal muscle due to reduced strain

Neutral Position

Refers to the body position that a person assumes in a normal upright, approximately hip-width stance. The range of motion of a joint is determined from the neutral position.

Oedema

(from Greek *oidema* = swelling): water accumulation, water retention; leakage of fluid from the vessels which accumulates in the intercellular space

O. metatarsalia

Ossa metatarsalia: metatarsal bone. These five long bones form the mid-foot. Each consists of the proximal base, the shaft and the distal head. The base forms the transition to the tarsal, the head the transition to the toe.

O. naviculare

Os naviculare: navicular bone. Bone of the tarsal.

Pathological

(from Greek *pathos* = pain; disease): abnormally (changed)

Perforation

(from Latin *perforare* = pierce): puncture or perforation of a tissue surrounding a body cavity. For example, pointed bones can pierce the covering tissue after an amputation if they are not rounded.

Phantom Pain

Phantom pain is felt after an amputation in the body part that is no longer there. The patient can usually locate it very precisely outside of the body.

Physiological

(from Greek *physis* = nature; *logos* = doctrine): concerning the natural life processes

Plantar

(from Latin *planta* = sole of the foot): concerning the sole of the foot, towards the sole of the foot

Plantar Fascia

Plantar aponeurosis. The plantar fascia originates at the calcaneus (Os calcaneus) and runs in a v-shape into the joint capsules of the metatarsophalangeal joints and the end tendons of the toe flexors at the metatarsophalangeal joint.

Plantar Flexion

Lowering of the foot. Countermovement of ↑dorsiflexion. Muscles that perform this movement are called plantar flexors.

Point of Heel Strike

point where the heel first touches the ground at initial contact

Pressure Peak

Pressure is applied to the sole of the foot when walking. The level of pressure depends on the load. In the case of a bony prominence, the pressure is particularly high. This high pressure value is called a pressure peak.

Proximal

(from Latin *proximus* = the nearest): positioned towards the centre of the body. The opposite of proximal is ↑ distal.

Push Off

Toe-off during pre swing. This accelerates the leg into a forward movement.

Ray

A ray consists of a midfoot bone and the associated toe phalanges.

Ray Resection

amputation of a complete ray at the base of the metatarsal bone

Sagittal Plane

(from Latin *sagitta* = arrow): plane that cuts through the body from front to back. Viewed from the front, the sagittal plane appears as a line.

Shear Forces

Shear forces are mechanical forces in which surfaces are displaced in relation to each other.

Shifting

motion of the prosthesis against the residual limb tip during gait

Soft Tissue Coverage

Covering the bones cut during an amputation with soft tissues such as skin, muscles or subcutaneous fatty tissue. For partial foot amputations performed from the dorsum of the foot, the resilient soft tissue structures of the sole of the foot can be used to cover the residual limb.

Spongiosa

(from Latin *spongia* = sponge): spongy bone interior made up of fine bone tubercles (trabeculae). The spongiosa bone is encased in a compact bone layer.

Static

(from Greek *statikos* = standing, causing to stand): the equilibrium of forces, concerning statics, in equilibrium, at rest, standing still

Static Friction

The motion of two bodies in contact is reduced by the adhesive property of their materials.

Residual Limb Revision

Recurrent amputation caused by complications on the residual limb. Thus, a residual limb revision results in a shortening of the residual limb.

Supination

(from Latin *supinare* = move backwards, lean back): outward rotation of the foot around its longitudinal axis or lifting of the outer edge of the foot. Muscles that perform this movement are called supinators.

Tarsometatarsal Joint

(from Latin *articulatio tarsometatarsalis*): Lisfranc joint line; articulated connections between the individual bones of the tarsus and the midfoot bones (ossa metatarsalia I-V)

Tibia

(from Latin *tibia* = "shinbone"): the stronger of the two lower leg bones, which is part of both the knee joint and the ankle joint

Tight/Positive Fit

In mechanical engineering, this term refers to the gapless meshing of two workpieces to prevent motion. In orthopaedic technology, the term tight fit is used when the upper edge of a device (e.g. prosthesis shaft) is connected to the anatomical structure (e.g. residual limb) without any gaps.

Transmetatarsal

(from Latin *trans* = beyond, above, *metatarsalia* = midfoot bones): in a transmetatarsal amputation, the amputation line runs through all five midfoot bones.

Transtarsal

(from Latin *trans* = beyond, above, *tarsus* = foot root): in the case of a transtarsal amputation, the amputation line runs through bones of the tarsus.

Upper Ankle Joint

(from Latin *articulatio talocruralis*): the upper ankle joint and the lower ankle joint are the two joints between the lower leg and the tarsus. It is a hinge joint composed of the tibia and fibula at the lower leg and the ankle bone of the tarsus. It is stabilised by a joint capsule and several ligaments. The upper ankle joint is mainly responsible for the plantar flexion and the †dorsiflexion of the foot.

Ulcer

(from Latin *ulcus*): abscess

Ventral

(from Latin *venter* = belly, body): abdominal, facing forward. If, for example, an ankle-foot orthosis is produced with a ventral shell, the shell is placed against the front of the lower leg, i.e. the tibia.

Wound Management

Structured, interdisciplinary wound treatment in a clinical setting. After an amputation, thorough wound management aims to shorten the wound healing process and increase the wound healing rate. This creates an optimal basis for the prosthetic treatment.

Abbr.	Source	Page	Abbr.	Source	Page
[Bau]	Baumgatner R, Stinus H (2001): <i>Die orthopädietechnische Versorgung des Fußes</i> . Stuttgart: Thieme.	5, 10, 15, 28	[Krn]	Kern U, Busch V et al. (2009): Prävalenz und Risikofaktoren von Phantomschmerzen und Phantomwahrnehmungen in Deutschland. Eine bundesweite Befragung. <i>Schmerz</i> 23(5): 479-488.	7
[Brü]	Brückner L (2009): Amputationen am Fußskelett und Hilfsmittelversorgung. <i>Trauma Berufskrankheit</i> 7 (Suppl. 1): 177-184.	7, 14	[Kob]	Kobayashi T, Leung AKL et al. (2013): The effect of varying the plantarflexion resistance of an ankle-foot orthosis on knee joint kinematics in patients with stroke. <i>Gait & Posture</i> 37(3): 457-459.	53
[Des]	Desloovere K, Molenaers G et al. (2006): How can push-off be preserved during use of ankle foot orthosis in children with hemiplegia – A prospective controlled study. <i>Gait & Posture</i> 24(2): 142-151.	55	[Krö]	Kröger K, Berg C et al. (2017): Amputationen der unteren Extremität in Deutschland – Eine Analyse auf der Grundlage von Daten des Statistischen Bundesamtes im Zeitraum 2005 bis 2014. <i>Deutsches Ärzteblatt</i> 114(8): 130-136.	6
[Dil]	Dillon MP, Fatone S et al. (2007): Biomechanics of Ambulation After Partial Foot Amputation: A Systematic Literature Review. <i>Proceedings</i> 8: 2-62	9	[Nol]	Nolan KJ, Yarossi M (2011): Preservation of the first rocker is related to increases in gait speed in individuals with hemiplegia and AFO. <i>Clinical Biomechanics</i> 26(6): 655-660.	55
[Dil2]	Dillon MP, Barker TM (2008): Comparison of gait of persons with partial foot amputation wearing prosthesis to matched control group: Observational study. <i>Journal of Rehabilitation Research & Development</i> 45(9): 1317-1334.	14, 30, 34, 40, 46	[Owe]	Owen E (2010): The Importance of Being Earnest about Shank and Thigh Kinematics Especially When Using Ankle-Foot Orthoses. <i>Prosthetics and Orthotics International</i> 34(3): 254-269.	54
[For]	Forczek W, Ruchlewicz T et al. (2014): Kinematic gait analysis of a young man after amputation of the toes. <i>Biomedical Human Kinetics</i> 6: 40-46.	9, 34	[Per]	Perry J, Burnfield JM (2010): <i>Gait Analysis – Normal and Pathological Function</i> , 2 nd edition. Thorofare: Slack.	8
[Gre]	Greitemann B. (2017): Technisch orthopädische Versorgung nach Amputationen am Fuß. <i>Trauma und Berufskrankheit</i> (Suppl. 2): 158-162.	8, 9	[Schä]	Schäfer M, Baumeister T (2019): Prothetische Versorgung nach Amputation im Fuß. <i>Fuß & Sprunggelenk</i> 17: 155-170.	15, 16, 17
[Kai]	Kaib T, Block J et al. (2019): Prosthetic restoration of the forefoot lever after Chopart amputation and its consequences onto the limb during gait. <i>Gait & Posture</i> 73(1): 1-7.	16, 17, 44, 50	[Spo]	Spoden M (2019): Amputationen der unteren Extremität in Deutschland – Regionale Analyse mit Krankenhausabrechnungsdaten von 2011 bis 2015. Zentralinstitut für die kassenärztliche Versorgung in Deutschland. <i>Versorgungsatlas-Bericht</i> Nr. 19/03.: Berlin.	2, 6
[Kai2]	Kaib T, Block J et al. (2018): Fallstudie zum Einfluss verschiedener Chopart-Prothesen auf das Gangbild des Anwenders. <i>Orthopädie Technik</i> 69(11): 18-22.	16, 17			



FIOR & GENTZ

Gesellschaft für Entwicklung und Vertrieb von orthopädietechnischen Systemen mbH

Dorette-von-Stern-Straße 5
21337 Lüneburg (Germany)

+49 4131 24445-0
+49 4131 24445-57

info@fior-gentz.de
www.fior-gentz.com